



KINGS PLAZA
BROOKLYN

TENANT CRITERIA

MACERICH®

VISION STATEMENT

Welcome to Kings Plaza.

It is our vision and mission at Macerich to distinguish ourselves through superior performance in retail development and continuous improvement of our portfolio, to meet the changing needs of our customers and the retailers we serve. Our commitment is to furnish a well-designed, well-maintained and well-marketed retail environment, capable of maximizing traffic and sales.

We are pleased to become partners with retailers, striving for the same goals. We are ready to facilitate communication and share our expertise with you to complete your store within expected timelines.

These criteria act as a guide for the design of all work by Tenants in conjunction with the provisions of the Tenant's lease with the Landlord. Tenants are encouraged to express their own unique design statement within the parameters of the Design Criteria as outlined in this manual.

National and regional "standard" Storefront concepts are respected to the extent that they meet the Design Criteria. However, Tenants should be aware that some concept modifications might be necessary to comply with the Center's Criteria.

The same is true for proposed designs that are overly similar to a neighboring Tenant's Storefront design. We wish to make the Mall as diverse and interesting as possible and enable each Tenant to make a singular statement with their design.



CRITERIA MAIN CONTENTS

1.0 **INLINE**
CRITERIA FOR ARCHITECTURAL, SIGNAGE, AND TECHNICAL DESIGN FOR INLINE RETAIL LOCATIONS.

2.0 **FOOD**
CRITERIA FOR ARCHITECTURAL, SIGNAGE, AND TECHNICAL DESIGN FOR INLINE FOOD AND RESTAURANTS.

3.0 **KIOSK**
CRITERIA FOR THE DESIGN AND CONSTRUCTION OF RETAIL AND FOOD KIOSKS.

4.0 **BUILDING DETAILS**
ARCHITECTURAL DETAILS, REQUIREMENTS AND REFERENCE PHOTOS BASED ON STORE LOCATION.

5.0 **DESIGN INSPIRATION**
SUGGESTED DESIGN MOTIFS AND INTRO TO KEY DESIGN ELEMENTS.

6.0 **PROPERTY INFO**
PROPERTY LOCATION, CONTACTS, UTILITIES OVERVIEW, OPERATIONS, AND LOCAL PERMITTING INFO.

7.0 **SUBMITTALS**
REQUIREMENTS TO SUBMIT CONSTRUCTION DRAWINGS, RENDERS, SIGN DRAWINGS, AND MATERIAL BOARDS.

8.0 **ADDENDUM**
SUPPLEMENTAL DESIGN AND CONSTRUCTION REQUIREMENTS AND DETAILS PROVIDED AS LINKS TO EXTERNAL DOCUMENTS.

i **INTERACTIVE NAVIGATION**

This Criteria is an interactive document. You may tap or click the top Navigation Bar or the Side Content Bar to navigate directly to that section.

This page serves as a hub to the various sections included in this Criteria.

The sections in this Criteria break down the key categories of information to understand the design and construction requirements to incorporate a successful retail experience. Refer to the overviews included in the left side bar to learn more about the content included in each section.

It is the responsibility of the Tenant, its contractors, subcontractors, architects, engineers, employees, and agents to comply with terms of the Tenant Criteria, including the supplemental documents included in the Addendum.

The intent of this Criteria manual is to:

- Accelerate the leasing process by providing quick answers to questions about specific requirements.
- Establish the design expectations and technical requirements.
- Establish a coherent design by carefully curating and integrating within the Center.
- Guide the design standards.
- Answer basic questions about the design and construction process.
- Save time by minimizing design reviews.



INLINE RETAIL CONTENT OVERVIEW

1.1

DESIGN

CRITERIA FOR ARCHITECTURAL DESIGN REQUIREMENTS FOR RETAIL STOREFRONTS AND INTERIORS.

1.2

SIGNAGE

CRITERIA FOR PRIMARY AND SECONDARY STOREFRONT AND WINDOW SIGN DESIGNS.

1.3

TECHNICAL

CRITERIA FOR TECHNICAL DESIGN ELEMENTS TO ENSURE YOUR STORE CAN INTERFACE WITH THE PROPERTY'S BASE BUILDING UTILITY SYSTEMS.

SECTIONS OF INTEREST

BUILDING DETAILS

Includes property reference photos and specific Storefront design details.

PROPERTY INFO

Includes information on the Property's building codes, area permitting, and required contractors.

SUBMITTALS

Outlines requirements on how and what to compile for submittals to the Landlord for design reviews.

DESIGN INSPIRATION

Provides visual inspirations for design aesthetics.

The Inline Retail Criteria provides key technical information and design requirements to ensure your store enlivens the consumer experience and interfaces with the Center.

The Tenant and the Tenant's Architect assume the following important obligations:

- Fulfill the intent of the Criteria both in concept and in detail.
- Determine and respond to the actual physical conditions of the Tenant's location.
- Maintain and enhance the high standards of quality established in the construction of the Center.
- Ensure the quality of execution of all design material, finish, and detail concepts in the construction of the Tenant's improvement.
- Provide the required detail at all transitions from Tenant Storefront to neighboring Storefronts, as well as to the base building.



DESIGN CRITERIA

☐ STOREFRONTS

- ☐ *ENTRY*
- ☐ *POP-OUTS / STOREFRONT HEIGHTS / NEUTRAL PIER / CONSTRUCTION*

☐ DESIGN CONTROL AREA

- ☐ *DESIGN REQUIREMENTS / WINDOW DISPLAY / PROHIBITED DESIGN ELEMENTS*

☐ MATERIALS

- ☐ *GLAZING / DECORATIVE GLASS*
- ☐ *WOOD / STONE / PLASTER*
- ☐ *METAL / LEATHER*
- ☐ *WALLCOVERINGS / SOLID SURFACE*
- ☐ *PAINT / FAUX FINISHES / FABRIC / TILE*

☐ INTERIORS

- ☐ *LIGHTING / FLOORING*
- ☐ *CEILING / WALLS & PARTITIONS*
- ☐ *EGRESS DOORS / RESTROOM*

SECTIONS OF INTEREST

- ☐ *BUILDING DETAILS*
Includes property reference photos and specific Storefront design details.
- ☐ *PROPERTY INFO*
Includes information on the Property's building codes, area permitting, and required contractors.
- ☐ *SUBMITTALS*
Outlines requirements on how and what to compile for submittals to the Landlord for design reviews.
- ☐ *DESIGN INSPIRATION*
Provides visual inspirations for design aesthetics.

Tenants are encouraged to express the individuality of their brand through excellent design by forward thinking design teams.

This Design Criteria focuses on strong design details visible from the Center common areas. Focusing on a strong Storefront design enlivens the retail experience and draws customers in to shop. Macerich's Design team is always excited to partner with Retailers in curating a unique and memorable shopping experience. Our team is available to collaborate on your enticing Storefront designs. The [DESIGN INSPIRATION](#) section is also a great launching point to explore design concepts and methods to engage customers.

- All Tenants must engage a reputable Architect.
- Design drawings must all be reviewed and Approved by the Landlord.
- All design elements and finishes must adhere to local and national building code requirements.



> STOREFRONTS

The Center's success is dependent on the creative design contributed by individual Tenants. It is vital that your Storefront design is integrated with the look and feel of the Center's aesthetic.

The [BUILDING DETAILS](#) section includes specific storefront design requirements based on your store's location. These location based requirements must be incorporated into your Storefront's final design.



> ENTRY

ENTRY

Your Storefront entry is a critical design feature to create an invitation to shop. As such all stores must express the entry as an identifiable part of the storefront. The underside of the entry portal soffit shall be finished to match the storefront.

SWING DOOR ENTRY

- Swing doors should be located in a recessed vestibule a minimum of 3' from the Storefront.
- No door swing shall project beyond the maximum allowable lease line.
- Minimum allowable door height is 9'-0".
- All other doors are to be hinged or pivot-type doors. Doors are suggested to be the height of the glazed Storefront.
- Recessed entry flooring shall match the Center's flooring requirements.

OPEN STOREFRONT ENTRY

- An open Storefront must also present an entry zone. Macerich will review all open Storefronts for alternate articulation and dimensional elements.
- Tenants choosing to have an open storefront are required to secure the premises after business hours with a coiling, sliding or folding security closure which complies with the following design guidelines:
 - Shall be set back from the lease line a minimum of 4".
 - Shall coil overhead or coil, fold or slide horizontally to retract into pockets or enclosures to conceal from view during business hours.
 - All supports, tracks, guides and operating devices must be concealed flush with adjacent Storefront finishes when closure is in the open position and be integrated into the Storefront overall design expression.
 - Horizontal tracks are not allowed in the floor surface.
 - Exposed locking devices or latches are not allowed. Key switches shall be concealed and mounted within the Tenant Storefront proper.
 - All supports to be provided by Tenant. Suspending closures from existing building structure is not allowed.



> POP-OUTS / HEIGHTS / NEUTRAL PIER / CONSTRUCTION

POP-OUTS

Three dimensional pop outs in both plan and height are required for all Storefronts in all new Tenant areas.

- When storefronts are visible from the upper level, special care must be taken so the top is finished to match the Storefront design.
- Exposed conduits, raceways, access panels or equipment may NOT be visible.
- All surfaces of any visible projections must also be finished to match.
- No dust or falling debris may collect on surfaces visible from upper levels. Tenant is responsible for the upkeep of all surfaces.
- Designs may incorporate sloping tops at no less than a 3 in 12 pitch to create a debris resistant surface.

STOREFRONT HEIGHTS

- All Storefronts must extend up to a maximum height of 11'-0" AFF.

NEUTRAL PIER

- Tenant Storefronts are to abutt each other, separated by a 3/4" black, recessed, C-channel reveal.
- Tenant under construction is responsible for the installation of the reveal between adjacent storefronts, if not currently existing. Neutral pier architectural details are located in the [BUILDING DETAILS](#) section.

STOREFRONT CONSTRUCTION

- All storefront construction shall be self-supported from the floor and independent of the building fascia and bulkhead structure.
- Storefronts may be braced to the overhead structure within the Tenant space.
- Connections to the deck, mall mechanical, electrical, plumbing, or fire protection equipment for support is not permitted. This includes ceiling splay wires.
- A 6" durable base is required along the entire Storefront.



> DESIGN CONTROL AREA

The Design Control Area (DCA) is the zone extended from the storefront lease line to 6'-0" inside your space, including all display windows and retail graphics, display fixtures, signs, materials, finishes, color and lighting fixtures within the area.

At Macerich, we take special interest in the DCA as an extension of the retail presentation and showcase of the store's merchandising. The intent is to convey excitement, and give the consumer a reason to shop.

Use of a professional Visual Merchandisers is highly encouraged. Design drawings shall have a display layout plan. The layout plan shall have cut sheets for fixture and/or mannequin types and include photographs of any existing Storefronts a Tenant may have that will enhance the layout plan. A rendering is required if photographs are not available.

Stores with both interior and exterior presence must activate both DCA areas. Tenants are encouraged to maintain open visibility into their Store to draw in Customers.



> REQUIREMENTS / WINDOW DISPLAYS / PROHIBITED ELEMENTS

DESIGN REQUIREMENTS

- Ceiling must be a hard surface.
- Lighting fixtures must be consistent with the character of the Storefront design.
- Recess all lighting fixtures.
- A minimal profile track lighting system matching the color of the ceiling plane is allowed.
- Hard bases on the walls are required, including any permitted pop out areas.

WINDOW DISPLAYS

Displays should be deliberate and integrated into the Storefront. Modulation of display systems and built-in architectural components will reinforce the design.

- Display cases must be adequately lit and ventilated.
- Digital monitors are permitted within 10'-0" behind glazing if integrated into the design and approved by Landlord. Coordinate with Tenant Coordinator for exterior applications and to confirm code or local requirements.

PROHIBITED DESIGN ELEMENTS

- Track lighting is not permitted in the DCA.
- Temporary signs for sales or clearances shall not be hung in the DCA or affixed to the glass inside or outside.
- No pegboard, slat wall or metal shelving of any kind may be placed in or extend into any part of the DCA.
- Security devices or freestanding pedestals are not permitted. They must be integrated and concealed.
- Carpet, vinyl or rubber materials of any sort will not be permitted within the DCA.
- Exposure of incandescent bulbs and/or fluorescent tubes are not allowed.



> MATERIALS

As an important aspect of presenting the Tenant's unique brand image, finish materials are to be composed, articulated and executed in a creative and quality manner.

All materials and applied finishes on the Storefront are to be high-grade, durable, non-corrosive and code compliant. They are to be maintained by Tenant at the Tenant's expense. All materials and finishes are subject to Landlord approval, and the inclusion of natural materials is encouraged.

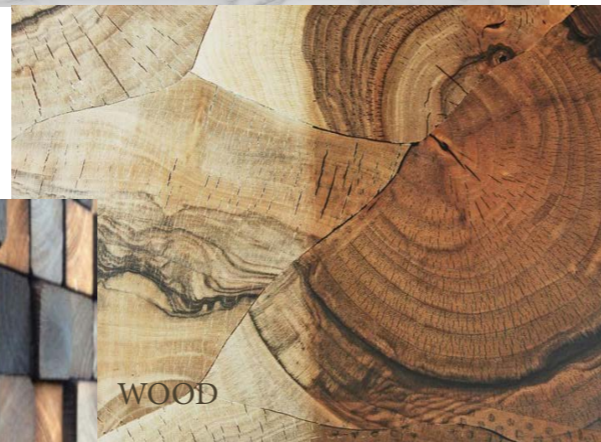
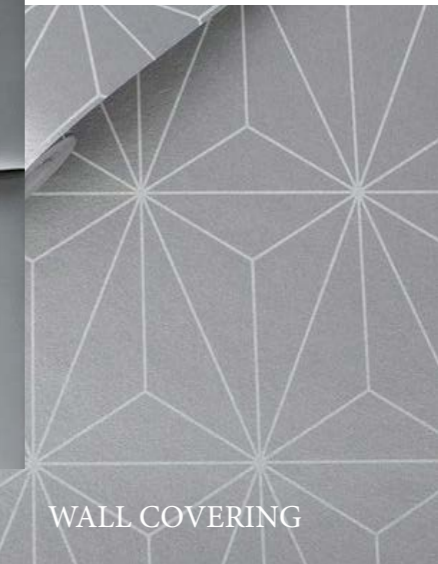

> GLAZING / DECORATIVE GLASS

GLAZING

Storefront glazing, particularly clear glazing, is a key component to establish design character and create an invitation for the customer to visit.

- A minimum of 60% of the Storefront is to be display windows with clear glass.
- Reflective glass (including extensive use of mirror) and/or tinted glass is not permitted on Storefronts or in the Storefront entry zone.
- Tinting or films applied after the glass is installed is prohibited.
- All glass shall be tempered. Glazing must be a minimum of ½" thick, and large panes of glazing must be of sufficient thickness to meet code and be properly supported.
- Tenants may be required to provide seismic clips to stabilize tall expanses of glass. Silicone sealant at glazing joints is not permitted.
- Butt-joint glazing is encouraged for show windows that in-fill larger Storefront forms. Glass shall be clear polished plate or tempered glass as required by code.
- Window mullions are required to meet all material and finish standards.
- Decorative glazing such as colored, beveled, sandblasted or etched glass may be used to create accent pattern and interest. Decorative glazing can be used as an accent, but must meet all material standards.

DECORATIVE GLASS

Decorative glass may be considered to provide a unique feature to the storefront.

- In frame-less assemblies, glass panel joint details edges must be polished, ground or chamfered. Glazing channels at corner conditions must be mitered.
- All exterior glazing units must have a solar heat gain coefficient (SHGC) of not more than 0.27 and a U-value of not more than 0.28.
- Exterior glass must be a minimum of 1" insulated, low E units. 0.27 and a U-value of not more than 0.28.



> STONE / PLASTER / DECORATIVE GLASS

WOOD

Wood material can be used for Storefront construction but must comply with all local and national code requirements.

- Applications of painted or stained wood may include window frames, decorative trim, molding and solid areas, such as decorative bulkheads. In some cases, it may be used for larger architectural elements, such as columns and entablatures.
- Wood paneling and plank construction are not acceptable unless presented in a highly imaginative concept and approved by the Landlord.
- Wood specified for interior Storefronts must be kiln dried, mill quality hardwood and must meet local flame spread requirements (Class III 76-200), as well as comply with all code requirements.
- Painted wood must have a shop quality enamel finish. Wood without a paint finish must receive a clear, preservative sealant.
- A mock-up of the materials, colors, textures, or application may be required at Landlord's discretion.

STONE

Granite, marble, limestone, travertine, slate, adoquin and other natural stone materials may be used for Storefront applications.

Stone may be polished, unpolished, sandblasted, flamed, honed, split-face or carved.

- Natural stone must be protected against staining and discoloration by means of sealers appropriate to the material.
- Craftsman-like attention to detail is required at all connections and transitions to other materials, and we recommend utilizing metal reveals for a clean finish.
- Corner and edge details must prevent visible unfinished edges. Exposed edges must be quirk mitered, chamfered or polished to match adjacent surface finish.

PLASTER

Cement plaster (stucco) and Venetian plaster finishes may be considered for limited storefront applications.

- Apply an even texture of light dash, sand or smooth finish.
- Plaster or stucco should not be the primary Storefront material. Finishes should be used in combination with other high quality materials.



> METAL / LEATHER

METAL

Metal panel may be used to provide alternate texture on a portion of the storefront.

- High quality is expected for all metal applications, including careful finishing and quality fastener detailing.
- Metals may include: shop-painted aluminum and steel, stainless steel, solid brass, bronze, pewter, or enamel coated steel, and may be used for hardware, trim and panels when well designed and detailed.
- The following notes on metal material details must be called out on the submitted drawing set:
 - Minimum 1/2" thick fire-rated plywood or other solid substrate is required behind all metal panels.
 - Minimum 18 gauge metal panels are required.
 - All seams between metal panels must be identified on the storefront elevation and must be properly addressed during design review process.
- The following metal surface treatments are not allowed:
 - Oil canning (resulting from light reflection on an uneven or buckled surface)
 - Scratches
 - Warps, dents, occlusions
 - Visible seams or other imperfections
- Reveals, turn-in seams, welding or similar must be specified and detailed for approval. Metal panels will not be allowed to directly come into contact with adjacent panel or other materials.
- No visible fasteners are permitted.
- Lap joints and seams must be even, straight, and concealed when possible. Outside corners are to be mitered or continuous break shaped.
- Sealants on natural metals are required to prevent tarnishing and must be maintained by Tenant at Tenant's expense.



LEATHER

The use of leather "tiles" for vertical application can add a level of depth and texture to the Storefront. However, these tiles should not be used at an elevation that can be reached by the general population due to the delicate finish and to prevent damage over time.

- The Landlord recommends keeping the use of leather tiles on the Storefront above 7'-0" AFF.

> WALLCOVERINGS / SOLID SURFACES

WALLCOVERINGS

Wallcoverings can add depth and texture to Tenant Storefronts, but need to be applied accordingly based on the durability of the product.

Vinyl, Paper, or Fabric Wallcoverings are not considered durable and are expressly prohibited in the use of Tenant Storefronts.

- Any wallcoverings located at pedestrian level (below 7'-0" AFF) must be extremely durable and rated by the manufacturer for high traffic use.
- Any wallcoverings located above pedestrian level (higher than 7'-0" AFF) must be durable and washable for maintenance purposes.
- Removable/repositionable wall coverings are not permitted for Storefront use.
- All wallcovering applications must appear seamless and be securely affixed with commercial grade adhesive rated for high traffic use covering the entire back of the product.
- All maintenance of wallcoverings is by Tenant. No peeling, bubbling, or other separation of the wallcovering from the applied substrate is permitted to remain, and is the responsibility of the Tenant to repair in a time frame deemed acceptable by the Landlord.



SOLID SURFACE

The use of large format solid surface panels can effectively mimic luxury materials in places where cost may be an issue (IE: Caesar Stone or Cambria), or to provide even, diffuse lighting elements in the storefront (IE: Lumicor or 3Form).

- All solid surface products must be rated for heavy duty commercial applications – residential quality products are not permitted.
- Joints, flat seams, and corner conditions of solid surface materials must be tight and seamless.
- All visible edges must be finished to the same level and quality as the front face of the material.
- If the body of the product is not consistent throughout, a mitered corner detail is required to keep the presentation clean.
- All corners and edges must be eased for safety purposes.
- No adhesive can be visible in the final application.



> PAINT / FAUX FINISHES / FABRICS / TILE

PAINT

- Surfaces should be maintained as an even and durable surface finish, at all times.
- Any paint application should show uniformity without evidence of touch-ups or batch variation.
- Paint should be colorfast, and well executed to prevent lap marks, brush marks, or poor coverage.
- Surfaces and materials shall be prepared and staged correctly to avoid problem conditions such as poor adhesion, sagging, chipping or flashing.
- Painted metal surfaces are not allowed.
- Painted gypsum board is not permitted on the Storefront.
- Painted MDF may be used with a finish process of 1 coat primer, 2 coats finish (sprayed and sanded between each step). Minimum thickness of the MDF is 3/4" on Storefronts.

FAUX FINISHES

Faux finishes may be used at the Landlord's discretion.

- Actual samples of the faux finish must be submitted to the Landlord. Photographs of previous examples are helpful but may not be substituted for an actual sample.
- Faux finishes must be executed by a commercial artisan specializing in that medium.

FABRICS

- Fabrics shall be commercial grade and tested in accordance with ACT Guidelines.
- Specifics for flammability and four aspects of fabric durability: Wet & Dry Crocking, Colorfastness to Light, Physical Properties, and Abrasion are to be documented for each fabric specified and available for Landlord review if requested.

TILE

- The Second Level is subject to considerable vibration. Specific material and installation requires for Tile on this level is detailed in the [TILE PROTOCOL](#) attachment in the [ADDENDUM](#).
- Tile may be used in diverse applications and is encouraged to introduce light, texture, and graphic quality to a Storefront.
- Porcelain, cermaic, or glass tile in glazed or natural finishes may be used as accents and in limited field applications. Patterns over a large area must be sophisticated and well executed.
- Small intricate mosaic tile may be utilized for detail and accents only.
- Lapped or butt joints are not permitted. Outside cornered must be bull nose edge or special corner trim.



> INTERIORS > LIGHTING / FLOORING

The store interior design should emphasize your merchandise and create an exciting experience for the customer.

It is the Tenant's responsibility to survey, capture and address all existing conditions within the space.

LIGHTING

Lighting can greatly contribute to the design of a Tenant's store, by emphasizing architectural forms as well as highlighting signage, adding color and visual drama to walls and other design elements. The creative use of dramatic lighting is encouraged at entries, show windows and merchandise displays.

- Fixtures must be positioned to avoid glare directed into public areas. Do not over light.
- Lighting fixtures in the DCA must be recessed downlights, MR16 low voltage or similar types. Fluorescent fixtures will not be permitted.
- Wall sconces or decorative lamping may be used to cast light onto storefront forms, provided that bare bulbs are not exposed and that the finish and form of these fixtures coordinate with the overall Storefront design. Fixture cut sheets are required.
- Sconces shall be commercial grade in quality and size.
- Residential scaled sconces are not acceptable.
- Colors are subject to Landlord approval.
- 2'x2' or 2'x4' prismatic fluorescent lights are not allowed.
- Track lights shall be finished to match the ceiling.
- Strobe, spinner, or chase type lighting is not permitted.

FLOORING

- Finished flooring is required in the full premises including in the recessed entry conditions and storage areas of the store.
- Hard surface base is required in all sales areas.
- Ensure floor material is durable and non-slip.
- Carpet must be commercial grade and meet local code required fire-proof ratings.
- Wood flooring must be hardwood with wear resistant surface.
- Exposed concrete floors must be sealed.
- Transitions between flooring and common areas must be flush.
- Tenant is responsible to mitigate any/all ADA issues and clear with the appropriate municipality.



> CEILING / WALLS & PARTITIONS

CEILING

- Stores 800 s.f or less must have a gyp board ceiling, not an acoustic panel ceiling.
- Recessed entry conditions must have a finished soffit matching the storefront.
- Concealed light covers to highlight architectural elements are encouraged.
- Multi-level ceilings are encouraged.
- Gypsum wallboard, concealed spline, decorative patterned ceiling panels, and other “high-tech” materials are encouraged.
- Standard 24” x 48” acoustical panels are not allowed in sales areas.
- Sprinkler heads are to be fully recessed in hard or acoustical ceilings.
- All ceiling material shall be non-combustible. No combustible materials may be used above the finished ceiling.

WALLS & PARTITIONS

- Demising walls are not designed to accommodate cantilevered or eccentric loads. If Tenant plans to use a demising wall for support of shelf standards, light soffits or heavy attachments, Tenant shall reinforce the wall as required by providing additional steel studs or independent supports for the shelf standards.
- Demising walls and ceiling shall be sound insulated to achieve a minimum STC rating of 50 by Tenants who produce above 80 dB (including but not limited to music stores, arcades, etc.) The Landlord will strictly enforce all Tenants’ right to quiet enjoyment of their Leased Premises.
- Tenant shall protect fire proofed columns and braces with gypsum board, and furr as required.
- The following are required for hair salons, pet shops and all food preparation type Tenants:
 - Walls containing “wet” areas to be constructed of metal studs with water resistant 5/8” type “x” gypsum board.
 - Demising walls of pet shops shall have sheet metal installed on studs, behind drywall, up 3’-0” from floor.
- When Tenant chooses not to install a ceiling within Tenant’s stockroom, Tenant shall extend the partition separating the stockroom from other areas of the store, to the underside of the structure above in order to isolate the stockroom from the sales area attic space. Tenant to verify if this is allowed by code.
- Metal or plastic laminate inserts are required for slatwall. No visible substrate at slats.
- Recessed wall standards are permitted.
- No open shelving with visible brackets or surface mounted systems are allowed.



> EGRESS DOORS / RESTROOM

EGRESS / SERVICE DOORS

- All retail spaces must provide two exits from the premises if required by code.
- All secondary exit doors shall be backset so that the door does not swing into the corridor, or exit passageway.
- Doors entering a common exit passageway or corridor shall be labeled with the Tenant name and space number.

RESTROOM

- Toilet facilities must meet all applicable ADA and building code requirements.
- 3" Floor drain and cleanout are required.
- Each restroom must have an exhaust system.
- A waterproof membrane beneath the finish floor surface up to a height of 4" along all walls is required.
- Floor finishes in toilet rooms shall be ceramic tile with a coved 6" base. Tenant is required to provide a waterproof membrane beneath the finish floor surface up to a height of 4" along all walls.
- Toilet room walls and ceiling shall be constructed of metal studs with water-resistant $\frac{5}{8}$ " type "x" gyp board.
- A water shut-off valve is required at eye level.



SIGN CRITERIA > CONTENTS

PRIMARY SIGNAGE

CONTENT / DESIGN ELEMENTS

PLACEMENT / DIMENSIONS / CONSTRUCTION

SECONDARY SIGNAGE

WINDOWS / THRESHOLD

AWNINGS / BLADES

PROHIBITED ELEMENTS

SECTIONS OF INTEREST

BUILDING DETAILS

Includes property reference photos and specific Storefront design details.

PROPERTY INFO

Includes information on the Property's building codes, area permitting, and required contractors.

SUBMITTALS

Outlines requirements on how and what to compile for submittals to the Landlord for design reviews.

ADDENDUM

Includes additional info on exterior signage requirements.

Storefront signs are vital to the successful function of the Center.

The goal of this Criteria is to produce a colorful collage of signage that tastefully informs, delights, and stimulates the shopper.

All sign materials must be consistent with the design theme, enhancing the storefront and evoking a positive retail image.

Due to the variety of architectural treatments within the Center, each Storefront sign will be carefully considered in relationship to its particular location. What may be appropriate in one location may not work in another. Each proposed sign will be evaluated on its originality and compatibility with neighboring signs, and its overall image within the Shopping Center.

The Landlord reserves the right to disapprove any sign design that is not compatible with these criteria and the aesthetics of the Shopping Center.

This Criteria is intended to harmonize with the leasing documents. It is the responsibility of the Tenant to forward a copy of these Criteria to their architect, contractor and various consultants.

No deviation from the enclosed Criteria requirements will be accepted without prior written approval from Macerich.

Signage design and construction must be code compliant.



> PRIMARY SIGNAGE

Your primary sign is an opportunity to express your Brand's identity and individuality at the entry portal of your store.

The following sign types are encouraged as design options for your primary signage:

- **REVERSE CHANNEL (HALO LETTERS)** minimum of 3" deep and projected from the background.
- **INTERNALLY ILLUMINATED** sign housings having unique shapes with letters routed out and formed letters protruding beyond the routed out letter.
- **EDGE-LIT, SANDBLASTED GLASS** with a continuous light source.
- **CAST METAL LETTERS** raised or flush with the fascia surface.
- **GOLD LEAF** on glass or stone.
- **SILK-SCREENED** glass or metal panels.
- **INDIRECT ILLUMINATION** on non-internally illuminated signs (artisan type panel signs).

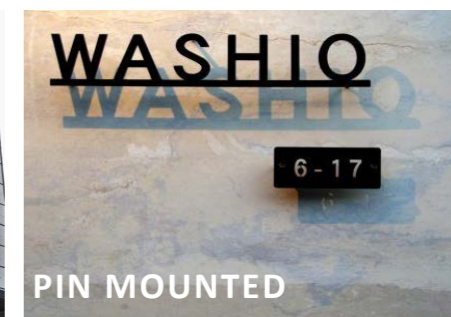
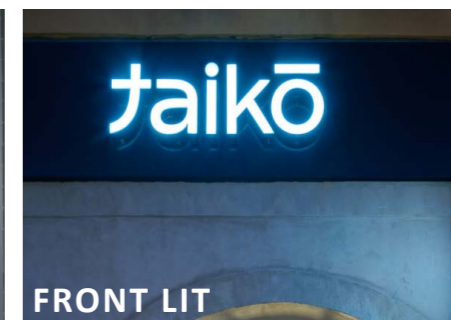
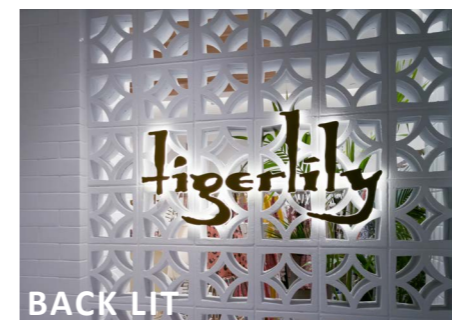

> CONTENT / DESIGN ELEMENTS

SIGN CONTENT

- Sign wording is limited to the Tenant's trade name and shall not include specification of merchandise sold or services rendered, regardless of the Tenant's legal name. Corporate crests, logos or insignia may be acceptable pending the Landlord's approval and provided they are part of the Tenant's name.

SIGN DESIGN ELEMENTS

- All primary Storefront signs must be illuminated. External illumination designs are subject to Landlord approval.
- Imaginative signs utilizing a variety of materials are encouraged. Adaptation of current sign practices may be necessary in order to comply with these criteria.
- Backlit components must be contained wholly within the depth of the letter. Maximum brightness may not exceed one hundred (100) foot-candles.



> PLACEMENT / DIMENSIONS / CONSTRUCTION

SIGN PLACEMENT

- One sign is permitted per store frontage unless additional signage is approved by Tenant Coordinator. Tenants occupying corner spaces may utilize one sign per elevation with a maximum of two (2) signs, or one sign on a diagonal corner. For unusually long tenant storefronts, more than one sign may be allowed, with Landlord approval.
- Bottom of sign to be at 9'-0" A.F.F. minimum.

SIGN DIMENSIONS

- Signs shall be designed as an integral part of the storefront, with letter size and location proportional to the overall storefront design, and in compliance with the Design Criteria.
- Letter size: must be proportional. Max allowed for height of letter is 13% of overall storefront height. Example - a storefront that is 12'-0" in height will be allowed to have a maximum letter height of 18.72".
- Letter dimensions of greater proportions may be considered if, in the Landlord's opinion, the sign design is of exceptional merit and architectural quality.

SIGN CONSTRUCTION/INSTALLATION

- All Storefront signage and lighting, both interior and exterior, are required to be on a separate circuit and controlled by a time clock. Storefront signage and lighting are required to be on during operating hours and off during non-operating hours. This includes exterior building Storefront signage.
- Electrical raceways are not to be visible.
- High quality fabrications are required. Hums, flickers and light leaks are not permitted. Attachment devices, bolts, clips, threaded rods, fasteners, tubes, raceways, conduit, and other mechanisms are to be concealed. All labels must be away from public view. Signs must comply with all codes and regulations, must bear the UL label, and must have current sign permits.
- Tenant may use Landlord bulkhead for lateral bracing only.
- Threaded rods or anchor bolts shall be used to mount sign letters spaced out from background pane. Angle clips attached to letter sides will not be permitted. All bolts, fastenings, and clips shall be of hot-dipped galvanized iron, stainless steel, aluminum, brass or bronze, and no black iron materials of any type shall be permitted.
- Advertising placards, banners, pennants, names, insignia, trade-marks and other descriptive material may not be attached to the storefront or glazing.
- Visible weep holes are not permitted.
- Any existing holes from previous Tenant signage must be patched and painted.



> SECONDARY SIGNAGE

In addition to the Primary Sign, all signage visible from the exterior of the store are considered Tenant Signs. These do not include messages used to advertise products, sales, or special events. Several various Secondary Signs are allowed at the Center and detailed in this section.

The following general Secondary Sign requirements must be met by all Sign varieties:

GENERAL

- Signs must be kept within the the lease line.
- Signs must be in proportion to the overall storefront and composition.

MESSAGING

- Trade name and/or logo only, are allowed.
- No taglines may be incorporated.
- Established logos will be allowed and will be counted in the overall area calculations.



> WINDOW / THRESHOLD

Secondary signage types and their requirements include:

STOREFRONT WINDOW SIGNS

If the Tenant wishes to provide additional Tenant identity, it is to be located at the pedestrian level on the inside face of the Storefront glass.

- Glazing signs are to be translucent (similar to frosted glass), reverse-reading and applied directly to the interior of the glass surface.
- Tenant graphics on Storefront glass shall be computer cut fat vinyl graphics (text/letter/logos)
- Maximum allowable area of signage is subject to Landlord's review and approval.
- Tenant graphics/logo will be limited to a maximum of three (3") inches in height.

THRESHOLD SIGNS

In addition to Storefront signs, Tenants are encouraged to incorporate signs into their entry way flooring. Landlord will review threshold signs on an individual basis.

- Threshold signs are to be graphics comprised of logos, crests and accent.
- Finish is to be flush with adjacent materials and consistent with entry flooring quality.
- Recommended materials are wood, tile, stone, metal and terrazzo inlays.
- Threshold signs are not to extend beyond their lease line into the Center.



> AWNINGS / BLADE SIGNS

AWNINGS

Some Tenant Storefront designs include projected awnings. Landlord will review awnings and their signage on an individual basis.

- Glass or metal are the preferred materials of choice, although fabric awnings will be considered.
- Awning signage may be considered as the main Tenant's identification at the sole discretion of the Landlord in the interior of the Mall only.
- Signage may occur on the valence of the awning and may be painted or silk screened in a contrasting color.
- Logos shall be silk-screened and submitted with awning and sign drawings. Size of the logo shall be proportionate to the overall width of the awning and subject to Landlord's approval.
- The lowest point of the awning or shade shall be a minimum of eight feet (8'-0") above the finished floor. It is the designer's responsibility to ensure that awnings conform to all applicable codes.
- Materials such as Pana-flex, plastic or other vinyl materials shall not be permitted.
- Awnings shall be cleared and maintained in good condition at the sole expense of the Tenant
- Wording on awnings is limited to Tenant's DBA only.

BLADE SIGNS

A blade sign is a double-sided sign mounted perpendicular to the building facade and suspended on a metal bracket, to be placed near the entrance(s) to a retail space.

Blade signs are subject to Landlord approval and may not be approved at all Store locations.

The following requirements must be followed for the design and installation of Blade Signage:

- Fabricated use of painted metal signs are encouraged.
- Minimum clear distance from the bottom of a projecting blade sign to a pedestrian surface shall be 9'. Tenant blade signs shall not project from the building face more than a maximum of 3'-6".
- Sign dimensions are limited to: 6 sq ft.
- Sign must be internally illuminated. Non-illuminated signs may be considered under special circumstances.



> PROHIBITED SIGNS AND MATERIALS

PROHIBITED SIGNS AND MATERIALS

The following sign types and materials are not permitted:

- Internally illuminated plexi-faced channel letters.
- Vacuum-formed or injection-molded plastic signs.
- Cabinet or standard “can type” signs with illuminated translucent backgrounds and silhouetted letters.
- Exposed skeleton neon applied directly to fascia element.
- Temporary or ‘sales’ signs attached to Storefront.
- Freestanding tripod signs.
- Flashing, scintillating, moving, sequencing, audible or odor producing signs.
- Paper, cardboard and Styrofoam signs.
- Credit card and advertising placards, decals, stickers or trademarks.
- Manufacturer labels.
- Carpet or rubber entry mat signs.
- Internally illuminated awnings.
- Signs employing un-edged or uncapped plastic logos or letters with no returns and exposed fastenings.
- No simulated materials (IE: wood grained plastic laminates, Zolatone etc.) or wall covering permitted.
- Signs painted on Storefront.
- No radioactive material shall be allowed to be used or installed as part of any Tenant construction scope of work. Furthermore, no radioactive signs such as Tritium exit signs shall be allowed in our Shopping Centers.

TECHNICAL CRITERIA > CONTENTS

ELECTRICAL

- POWER SOURCE / METER
- REQUIREMENTS
- DATA & COMMUNICATIONS
- LIGHTING

LIFE SAFETY

- SPRINKLER
- FIRE ALARM
- EGRESS

PLUMBING

- METER / REQUIREMENTS
- GAS

MECHANICAL

- GENERAL / HEAT RECOVERY / ROOF EQUIPMENT
- GENERAL HVAC / EXHAUST / SMOKE PURGE
- DUCTWORK / FOOD SERVICE
- NOISE / VIBRATION

STRUCTURAL

SECTIONS OF INTEREST

BUILDING DETAILS

Includes Property reference photos and specific Storefront design details.

PROPERTY INFO

Includes information on the Property's building codes, area permitting, and required contractors.

SUBMITTALS

Outlines requirements on how and what to compile for submittals to the Landlord for design reviews.

ADDENDUM

Includes additional info on exterior signage requirements.

The Inline Technical Criteria provides buildings details and design requirements for the Center's technical systems.

It is the Tenant's responsibility to verify existing conditions and comply with all applicable codes and standards for technical systems.

Tenants are required to adhere to the full Criteria during their design and construction.

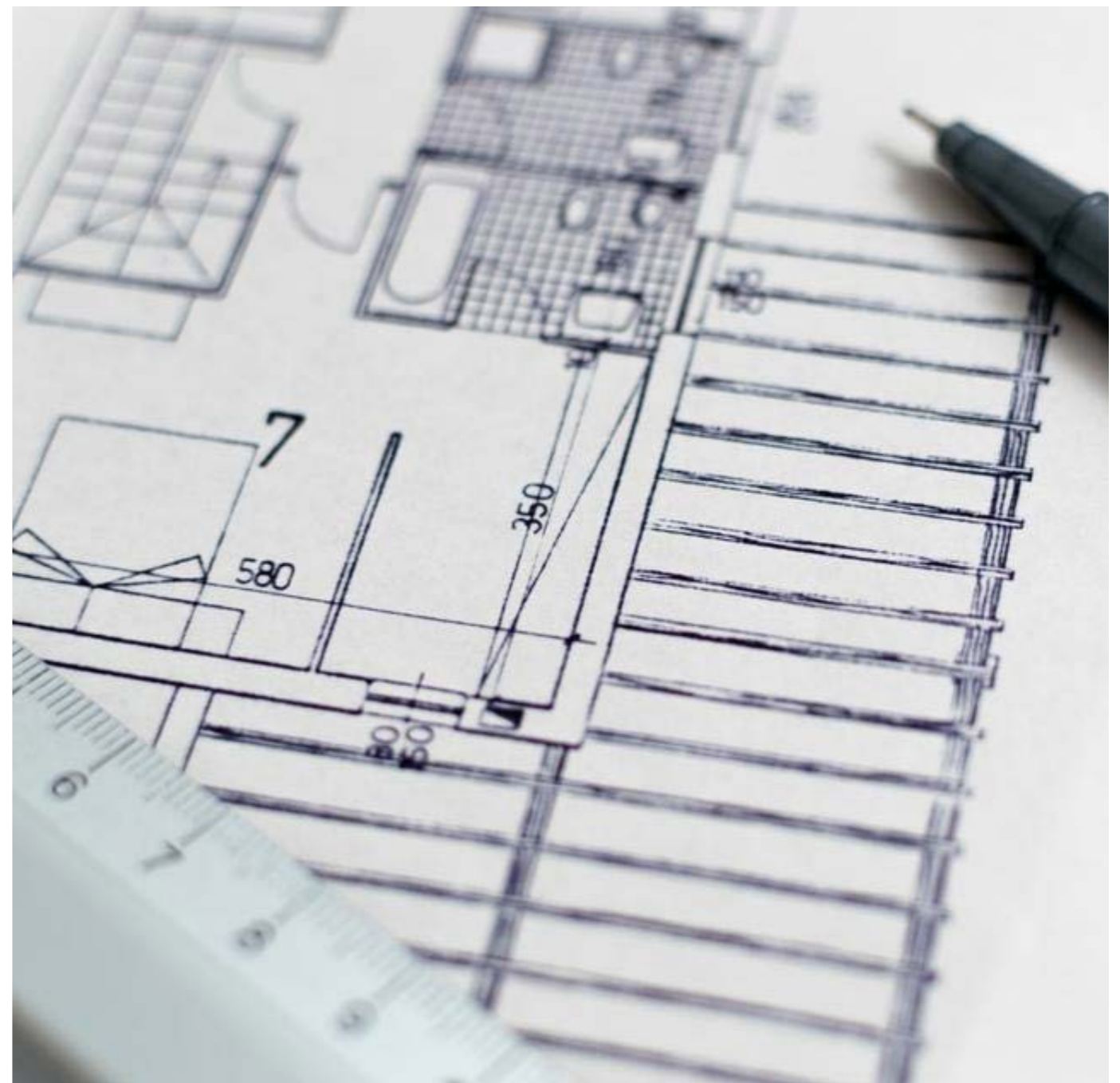

> ELECTRICAL > POWER SOURCE / METER

PROVIDED POWER SOURCE

Landlord will provide for Tenant electrical service connection in the switchboard room with spare breaker. Landlord may furnish an empty service conduit(s) from Landlord's service area to a location within or near Tenant's Demised Premises selected by Landlord.

Landlord provided electrical service for Tenants is based on twenty (20) wats per square foot of floor area of the Tenant Space for retail shops and thirty-five (35) wats per square foot for food service.

TENANT REQUIREMENTS

Tenants must meet the following requirements related to connecting to their power source:

- Service conduit shall terminate at location determined by Landlord. Where Landlord has not provided a service conduit, Tenant Contractor shall install to Premises. At grade level electrical conduit may be installed at least 4" under the slab and must be in Schedule 40 PVC conduit. Conduit is never allowed to be installed in slab or less than 4" below slab.
- All Tenant electrical metering is a redistribution by Landlord, Tenants to install new meter per required specification from Source One. The Landlord is the Tenant's electrical utility contact.
- All conduits shall be concealed in finished areas. Minimum conduit shall be one-half inch (½") diameter. All conduit concealed under slab shall be three-fourths inch (¾"). No conduit shall be allowed to be installed in the slab unless approved by Landlord.
- As required, Tenant shall place properly sized main-fusible disconnect switch with fuses, or main circuit breaker in panel boards, within the Demised Premises.

Tenants with a service size of 200 amps or below shall provide the following:

- Properly sized fuses in the main fusible disconnect switch or circuit breaker (minimum of 100 amps) in Landlord's switchboard.
- Provide a meter base and meter, per New York Power Authority requirements and as directed by Landlord.
- Tenant to extend, as required within the Tenant Space, the electrical service conduit to Tenant's main disconnect switch or main circuit breaker equipped panel board.
- Tenant shall install four (4) properly sized copper conductors from Landlord switchgear, through the Landlord conduit to the Tenant main disconnect device within the premises.

Tenants requiring a total electrical load of 201 amps and above shall furnish the following:

- Free-standing, single-section, indoor-type, front-accessible switchboard with a Current Transformer (CT) compartment and meter socket on the front panel, fused main disconnect switch and properly sized fuses. All out going conduits shall be through top of section. Tenant shall provide CT cabinet and metering as per New York Power Authority requirements to be installed in the Tenant premises.
- A main fusible disconnect switch, to be installed by Landlord's electrical contractor at Tenant's sole cost and expense.
- Where applicable, Tenant's engineer to design sized KVA transformers where voltage is stepping down.

METER DETAILS

Electrical scope to include new upgraded wireless sub-meter for electrical service to accurately monitor electricity for consumption and billing. The use of mall required vendor for either the purchase or commissioning of electric sub-meters is not required

ELECTRIC METER REQUIREMENTS

- **REVENUE GRADE** meters are required.
- **DISPLAY** must be at least 6-digits.
- **METER MUST READ** demand (kW) and usage (kWh).
- **METER MUST CAPTURE** the electric usage of the entire Tenant space, including HVAC units. If this is not possible, then it must be noted.
- **METERS WITH CT** must note if a multiplier is required and what the multiplier is on the face of the meter.

EXISTING METERS

If there is an existing electric sub-meter in the Tenant's space:

- **RECOMMISSIONING** the meter is the Tenant's responsibility to ensure proper installation and functionality or;
- **NEW METER** may be installed by the mall required vendor, and will be at the Tenant's sole cost.

> REQUIREMENTS

SYSTEM REQUIREMENTS

- All homeruns to panels are to be rigid conduit or EMT (compression fittings required) within space. In Plaza common areas, rigid conduit to be used in location where the height of the conduit is 7'-0" AFF or less, subject to Mall Management. All wiring within the demising walls shall be installed in conduit.
- "BX" or "MC" is acceptable within partition walls only, for runs not greater than 6'-0" in length. "ROMEX" type wiring shall not be permitted.
- All wiring shall be copper only. All conductors are to have 600-volt insulation, type THW, THWN, or THHN.
- Minimum wire size shall be No. 12 AWG excluding low voltage wiring.
- All wiring shall be color coded per NEC. Same color shall identify same phase throughout the system.
- Any exposed low voltage wiring must be plenum rated.
- Tenant shall provide flexible metal conduits only for connections to vibrating equipment, lighting fixtures, show cases, etc., as required, maximum length six feet (6'-0"), minimum one-half inch (½") electrical trade size. Furnish liquid-tight flexible conduits for outdoor installations. Install all flexible conduit in accordance with NEC.
- Watertight fittings shall be furnished, as required by NEC.
- Motors ½ HP or less shall be 120 volts, single phase. Motors ¾ HP or more shall be 208 volts, 3 phase or 480-volt 3 phase as applicable.
- Main service feeders shall be treated for the sum of all loads, plus twenty-five percent (25%) spare capacity at a minimum. Branch conduit connected loads shall not be in excess of eighty percent (80%) of rated capacity.
- Panel connected loads within the Tenant Space and main feeder conductors (from Landlord switch gear to panel) shall be balanced within plus or minus ten percent (10%) across all phases.
- As required by governing codes, Tenant shall furnish exit and emergency lights throughout the Demised Premises.
- Provide weatherproof disconnect switch and 120-volt duplex service outlet on all roof-mounted HVAC units.
- Conduit and raceway hangers, clamps, light fixtures, junction boxes, supports, etc. shall be fastened to joists or beams. Do not attach anything directly to the upper level slab, roof deck, piping or ductwork above.
- The electrical system serving the Tenant Space shall be grounded in accordance with the latest requirements of the NEC. System shall be grounded to the main cold-water pipe and structural steel in the Demised Premises, where applicable. Ground fault circuit interrupters shall be installed in branch circuits, where required by code.
- Manual or magnetic starters, switches, contacts, relays, time switches, safety devices and other controls shall be commercial type with heavy-duty ratings and shall be installed in strict conformance with the manufacturer's recommendations and applicable codes.
- Voltage drop, based on actual loads, shall be indicated on the one-line riser diagrams for all feeders and sub-feeders, per NEC. Furnish flexible conduits only for short connections to vibrating equipment, lighting fixtures, show cases, etc., as required. Minimum size is one half inch (½") diameter.
- As required, provide lock-on devices on panel circuit breakers for exit and emergency light and fire/smoke alarm system. Furnish a complete type written identification directory card for all main and branch circuits in the panel door.
- All devices and equipment in finished areas shall be flush mounted where possible. No lighting can be installed out-side the Tenant Space, in the common area, and/or ceiling for storefront lighting or sign illumination.
- Prior to making any conduit, pipe or duct-roof penetration and/or positioning any equipment on the roof, all the proposed locations and/or penetrations shall match locations, as indicated on the Landlord approved plans, and be approved by Landlord's on-site representative.
- All necessary roof penetrations made by required Landlord roofing contractor, coordinated with Tenant's General Contractor at Tenant's expense, shall be subject to Landlord's approval.
- Weatherproofing of any installation shall be performed by Landlord's authorized roofing contractor. Tenant's General Contractor shall pay all costs directly to such roofing contractor. Tenant's General Contractor shall be required to provide temporary weatherproofing for all roof penetrations until Landlord's roofing contractor has made the final patch.
- Tenant's electrical contractor shall furnish an identification nameplate on Tenant's main disconnect switch in Landlord's switch board. Nameplates shall be one-eighth inch (⅛") thick plastic, black on white, and etched letters. The minimum size shall be one inch (1") with only the Tenant's space number engraved on such, permanently affixed.
- All materials are required to be new and of commercial grade and have affixed Underwriter's Laboratories labels, where such labeling applies. All conduits shall be galvanized rigid heavy wall steel, or EMT. Sizes shall be determined per NEC. Watertight fittings shall be provided, as required by code.
- Pull boxes or junction boxes are required to be minimum twelve (12) gauge galvanized steel. Boxes in wall shall be galvanized pressed steel or cast metal. Caulk around boxes to eliminate noise transmission is mandatory.
- Lighting panels shall have quick-lag molded case breakers bolted to buss. Half-size or tandem breakers or plug-ins are not allowed. Distribution panels shall be either fusible type (with quick-make, quick-break interrupter switches) or molded case breaker type.

> DATA & COMMUNICATIONS / LIGHTING

DATA AND COMMUNICATIONS – INSTALL AND PROVIDER REQUIREMENTS

Telecommunications service is provided and administered throughout the Center by Granite Grid. The service includes a dedicated concierge customer service representative for each Tenant, high-bandwidth service (tailored to suit Tenant demand), centrally coordinated installations, moves and repairs.

- **ACCOUNT SETUP AND SERVICE INSTALLATION** is the Tenant responsibility to coordinate direct through Granite Grid. Other data providers are not permitted at this property as they do not have an access agreement in place. **It is highly recommended to coordinate service install a minimum of 4 weeks in advance.**
- **TELEPHONE DEMARC WORK** must be performed by Landlord's approved telephone subcontractor.
- **TELEPHONE SERVICE** is the Tenant responsibility to contact the local Telephone Company and install within their premises.
- **LANDLORD WILL PROVIDE** main telephone terminal board at a location outside the Tenant Space, selected by Landlord, for Tenant connection to telephone service. Landlord may furnish empty conduit from the main telephone terminal board to the Tenant's demised premises. Service conduit shall terminate at a location determined by the Landlord.
- **TENANT SHALL FURNISH** and install complete wiring within the Demised Premises for the telephone system, including backboard cabinet, outlets and service cable to the Tenant Space from the main terminal board located outside the Demised Premises.

LIGHTING – SYSTEM REQUIREMENTS

Tenants are required to upgrade their lighting system to meet or exceed new york city energy conservation code in accordance with new york city council file number int 1165-2016.

Lighting designs shall be submitted and approved by the landlord and local authority prior to tenant build-out. The landlord reserves the right to back charge installation fees to tenant found not to be in compliance with new york city energy conservation code.

- **LIGHTING IN TENANT SPACE** is the Tenant's responsibility. The Tenant will not install any lighting outside the Tenant's space with the exception of Mall required standard lighting at back doors. These fixtures shall be photo cell controlled.
- **LIGHTING SCHEDULE** is required for review in conjunction with a reflected ceiling plan.
- **TIME CLOCK** is required to control display window lighting and be on during the hours the Shopping Center is open.
- **DISPLAY WINDOW LIGHTING** at the ceiling must be glare-free and at approved levels at the storefront glass line and not hang down below the top of storefront glass.
- **RECESSED INCANDESCENT DOWN LIGHTS** are permitted.
- **DECORATIVE LIGHTING FIXTURES** for storefront illumination, such as luminous ceilings, chandeliers, pendant or wall units or clear type glitter strips are permitted if approved by Landlord. No strobe, spinner or chase type lighting shall be used.
- **CODE REQUIRED LIGHTING** such as exit, emergency and night lights must be provided throughout.
- **SALES AREA FLUORESCENT LIGHTING** must be recessed and must use metal parabolic louver type lenses with a minimum of 18 cell configuration for a standard 2' x 2' fixture. Bare lamp fluorescent or fluorescent fixtures with acrylic prismatic lenses may be used only in concealed areas or stock rooms.
- **TRACK LIGHTING** may be used if the track is painted to match the ceiling color.
- **LIGHTING CONTROL SYSTEM** is the Tenant responsibility, including connection to the Building Management system and connection to the Fire Alarm system.

> LIFE SAFETY > SPRINKLER SYSTEM

SPRINKLER SYSTEM REQUIREMENTS

Tenant shall connect a fire protection system, to either Landlord's sprinkler main or a branch line connection to the Tenant Space, using approved mechanical fittings. Tenant shall furnish all branch piping and sprinklers required to complete the sprinkler system within the Demised Premises. Tenant's sprinkler system design in remodel areas shall be based upon a single source of supply, Ordinary Hazard hydraulically calculated system as outlined in NFPA #13, FDNY and Landlord's insurance carrier's requirements:

- Density – 0.19 gpm/square foot.
- Operating Area: Hydraulically most remote 1,500 square feet (the location at partitions shall be ignored when choosing the remote area).
- Temperature Rating: 165° F.
- Orifice Size: one-half inch (1/2") or 17/32" (no mixing orifice sizes).
- Sprinkler Spacing: 130 square feet maximum.
- Hose allowance: Hose stream allowances are not required within Tenant system calculations. Hose stream allowances have been included in the calculations for the service main.
- Water supply available at the Tenant connection to service main will depend on the location. Landlord shall supply tenant with hydraulic nodes as required.

Tenant shall furnish an inspector's test connection. The test connection shall be installed of the most remote sprinkler, as physically possible, from the sprinkler supply main or capped outlet connection located in the Tenant Space.

Inspector's test connection shall be equipped with a one inch (1") corrosion-resistant shut-off valve, and minimum three quarter inch (3/4") hose bib connection with five feet (5'-0") length of hose piped to discharge to a suitable sanitary sewer receptor within the Demised Premises. All sprinkler system tests shall be witnessed by Landlord's On-Site Representative and local jurisdictional authorities, as required.

All piping shall be supported from the top chord of beams or joists only. Do not attach anything directly to the upper level slab or roof deck. Fastening and/or suspension devices shall be attached to the building structure only. Final connection to the Landlord's sprinkler main shall not be made until the entire system within the Tenant Space is pressure-tested and ready for service.

All piping shall be designed in accordance with NFPA #13 and installed per Landlord's insurance carrier's requirements.

All piping shall be threaded schedule 40 black steel meeting ASTM A135. All pipe fittings are required to be pressure class 175.

All hangers are to be of an approved type and spaced in accordance with NFPA #13. (Seismic bracing to be installed per I.B.C)

Tenant shall provide appropriate type fire extinguishers in stock room areas and elsewhere throughout the Tenant Space, as required by all local authorities having jurisdiction and Landlord's insurance carrier. Fire extinguishers shall be furnished, as directed by the Fire Marshal, and be easily accessible. Fire extinguishers shall be serviced and inspected periodically. The entire installation is required to be performed by a licensed sprinkler contractor in a first-class, workman-like manner.

Tenant shall not be allowed to stock the Demised Premises until the entire sprinkler system has been inspected, approved and put into operation. All materials and equipment under this section shall be new and listed by Under-writer's Laboratories, Inc. and Factory Mutual for fire protection system installation, and approved by all authorities having jurisdiction and governing codes.

SPRINKLER SYSTEM REQUIREMENTS FOR FOOD TENANTS

All the items indicated within the Fire Protection System General Requirements apply with the following additional criteria:

- All walk-in coolers/freezers shall be supplied with non-freezing sprinklers.
- Demised Premises with exhaust hoods, grilles and/or cooking facilities shall be equipped with a fire extinguishing system, including an alarm system. Furnish specific details on the sprinkler plans. Sprinkler system shop drawings shall be approved by the local authorities prior to the installation. The sprinkler system shall comply with all applicable sections of the NFPA #96 pamphlet. Upon activation of this system all cooking equipment is required to shut down automatically.
- Connected to Landlord's Fire Alarm System at Tenant's expense.

> LIFE SAFETY > SMOKE & FIRE ALARM

FIRE ALARM SYSTEM

Landlord will provide a fire alarm system as follows:

- A central fire alarm system serving the business center.
- A fire alarm junction box and SIGA-CT Addressable Modules for Tenant's system connection.
- The junction box and SIGA-CT Addressable Modules shall be located by Landlord.
- Landlord's fire alarm contractor shall make final connections and all associated EST-3 program updates related to the interconnection to Landlord's fire alarm system at the Tenant's sole cost and expense, and update per the latest NYFD code.

FIRE ALARM SYSTEM REQUIREMENTS

Tenants shall furnish all fire alarm devices from New York Fire Detection, Inc. (required) to be connected to the Landlord's EST-3 Fire Alarm and Life Safety Network System including:

- An EST/Edwards fire alarm control panel with Initiation Device Circuits (IDC) and Notification Appliance Circuits (NAC) configured for a minimum of 24 hours standby power followed by 5 minutes of a full load alarm condition
- All Tenant initiation devices shall be addressable (connected to the building system) utilizing Signaling Line Circuits (SLC) for all initiation devices.
- Smoke detectors shall be in accordance with NFPA-72 as follows:
 - Electrical closets/rooms
 - Tenant stockrooms
 - Tenant sales areas
 - In all areas where required by local Authorities Having Jurisdiction or other governing laws, codes or standards.
- Duct smoke detector(s) shall be installed as required by the International Mechanical Code (IMC) in accordance with NFPA-72.
- A waterflow switch and tamper switch shall be installed by the Fire Sprinkler Contractor on the sprinkler main at point of entry into Tenant's Demised Premises. The waterflow and tamper switches SHALL BE readily accessible for recurring inspection, testing and maintenance. The condition of the location of the switches SHALL BE carefully coordinated with the Fire Sprinkler Contractor and the Landlord's General Contractor.
- An approved inspector test valve IS REQUIRED TO BE PROVIDED by the fire sprinkler contractor in accordance with NFPA-13 section 8.17.4.2 to appropriately and efficiently test the required waterflow device. A test connection utilizing a hose is prohibited.
- A recessed strobe light shall be located at the storefront ceiling adjacent to the storefront lease line and visible from the Center Common Area.

- An HVAC shutdown relay shall be provided and configured in accordance with NFPA-72.
- Provide all wiring in accordance with most recent editions of NFPA-70, The National Electric Code (NEC), and NFPA-72, The National Fire Alarm and Signaling Code and as indicated in Tenant Fire Alarm Panel Interface Diagram.
- Initiating Device Circuit (IDC) and Signaling Line Circuit (SLC) wiring to be 18-gauge FPLP, Class B, Notification Appliance Circuit (NAC) wiring to be 14-gauge FPLP, Class B.
- A Tenant utilizing kitchen hood(s) is required to have an independent fire suppression system within the hood(s) and is required to connect the suppression system to Landlord's fire alarm system. (For final connections, see Landlord Work.) Tenant shall install and independent fire suppression system and provide conduit and wire to Landlord's SIGA-CT Addressable Modules.
- Wiring, as specified by the Fire Alarm Manufacturer and Authorized EST/Edwards fire alarm equipment distributor.
- Alarm sounders shall be audible from the Center Common Area.
- All zones shall be clearly labeled on the Tenant fire alarm control panel. Separate initiation device zones shall be provided for smoke detectors, manual pull stations, duct smoke detectors, heat detectors, water flow switches, and tamper switches. If Tenant Space occupies more than one level, additional zones shall be provided so that the separate initiation device zones are assigned to each level independently.
- Tenant shall furnish a fire watch and portable fire extinguisher minimum size 2A:20BC whenever any welding is done within the Demised Premises. The person performing the fire watch shall remain in the Tenant Space for at least one (1) hour after the completion of any welding.
- Before any work or demolition commences, Tenant or Contractor must reach out to Mall's required fire alarm vendor in advance to properly safe off fire alarm system as required.
- All new Tenants must have the FA vendor test and inspect the FA system regardless of construction scope. Mall's FA panel must be updated to indicate new Tenant name.
- Pull station required per code. If a pull station does not exist, one must be installed (if there is an alteration to the fire system. Not required if there is not a fire system alteration).

> LIFE SAFETY > SMOKE & FIRE ALARM / EGRESS

FIRE ALARM SYSTEM SEQUENCE OF OPERATIONS

The shutdown/loss of power to Tenant's panel shall initiate a trouble signal at the Tenant's panel and Landlord's main fire alarm panel. The sub panel for the Tenant fire alarm system shall transmit all signals, alarms, troubles and supervisory conditions to the Landlord's EST-3 Addressable Fire Alarm and Life Safety Network. The Mall EST-3 shall provide the of premises signaling and Fire Department Notification.

When required, all Tenant panels shall transmit each signal individually as distinct outputs to the SIGA-CT modules. Activation of the Tenant's water flow switch, manual pull stations, smoke detectors and heat detectors are required to initiate an alarm signal at the Tenant's fire alarm control panel that shall then:

- Produce sprinkler signal at the Tenant's panel and Land-lord's EST-3 fire alarm network panels
- Activate the Tenant's audible and visual alarm indicating devices.
- Shutdown all required HVAC systems(s).

Activation of the duct smoke detector shall initiate a supervisory signal to Tenant's fire alarm control panel that then shall:

- Produce a smoke signal condition at Tenant's panel and Landlord's EST-3 fire alarm network panels.
- Shut down all required HVAC system(s).

Activation of the fire sprinkler valve tamper shall initiate a supervisory signal to Tenant's fire alarm control panel that then shall:

- Produce a supervisory signal condition at Tenant's panel and Landlord's EST-3 fire alarm network panels.

Note: The fire sprinkler valve supervisory and duct detector supervisory shall be independent and distinct signals transmitted to the Landlord's EST-3.

The activation of the kitchen-hood fire-suppression system then would send an alarm signaling directly to Landlord's main fire alarm panel and Tenant fire alarm panel simultaneously.

FIRE ALARM SYSTEM TESTING

Each Tenant fire alarm system shall be acceptance tested in accordance with NFPA-72 by the EST/Edwards equipment supplier PRIOR TO REQUESTING final inspections with the FDNY. The EST/Edwards Fire Alarm equipment supplier shall provide a printed and electronic copy of both the NFPA-72 Fire Alarm and Emergency Communication System Record of Completion and the Fire Alarm and Emergency Communication System Record Inspection and Testing Form to be stored at the fire alarm panel prior to the FDNY inspections which shall be scheduled with and witnessed by Landlord's on-site representative. Written approval of the Tenant's fire alarm system and operation shall be obtained from the Building Department and the FDNY offices and a copy shall be submitted to Landlord's on-site representative.

- The fire sprinkler waterflow and valve tamper switches MUST be readily accessible or the waterflow and valve tamper switches will be required to be relocated to an accessible location at the Tenant's sole cost and expense.
- The fire sprinkler waterflow test SHALL be conducted utilizing an approved inspector's test valve arrangement in complete compliance with NFPA-13. If the test valve is not provided as required, it shall be installed at the Tenant's sole cost and expense. A test connection utilizing a hose is prohibited.

FIRE ALARM SYSTEM FOR FOOD TENANTS

All the items indicated within the Smoke/Fire Alarm System General Requirements apply, along with the following criteria:

- Heat detectors may be utilized in place of smoke detectors in the Food Tenant Demised Premises. An evaluation conducted by a NICET Level IV Fire Alarm Senior Engineering Technician shall investigate potential sources of ambient smoke, moisture, dust or fumes to determine if heat detectors should be installed rather than smoke detectors to minimize nuisance alarms in such areas. The intent to install heat detectors rather than smoke detectors shall be submitted to and approved by the FDNY.

EGRESS REQUIREMENTS

Distribution of utilities through a newly constructed or an altered exit passageway is prohibited except for equipment and ductwork specifically serving the exit passageway, sprinkler piping, standpipes, electrical raceway for fire department communication and electrical raceway serving the exit passageway.

> PLUMBING > METER / SYSTEM REQUIREMENTS

SYSTEM OVERVIEW

Tenant shell spaces are typically provided a sanitary sewer service main line and four-inch (4") plugged wye (Y) connection shall be installed beneath the slab and/or grade of the Demised Premises, at a location and invert elevation selected by Landlord. The Landlord shall provide a minimum three-fourths inch (3/4") cold water service system and valved outlet connection within or adjacent to Food Service lease spaces. A four-inch (4") sewer connection shall be located below grade or slab for Food Service lease space.

Tenant shall design and develop a complete plumbing system with all the necessary facilities to serve the Demised Premises. This includes installing a sanitary sewer system, a domestic hot and cold-water system and gas system, if required. Tenant shall make all connections to the existing utility services provided by Landlord.

Sanitary sewer vents are required to be routed and connected to the existing sanitary sewer vent system (where available) to lower level Tenants or run along the rear demising walls and building columns, if possible, and through the upper level and roof, as directed by Landlord.

WATER METER REQUIREMENTS

The Mall is master metered. Tenant is required to install a remote meter.

- **INSTALL** must be by a Landlord approved electrician.
- **SIZE** of the meter should match the size of the water line being served, or the meter can be 1/4" smaller than the line. For example, if a 1" water line servicing the space, a properly sized meter would be 3/4" or 1"
- **VERIFICATION AND APPROVAL** of install must be obtained by the Operations Manager, or a member of the Operations staff at the property.
- **PROOF OF INSPECTION** sent to the Tenant Coordinator including:
 - Date of installation or recommissioning
 - Meter make and model
 - Picture of the meter at time of installation or recommissioning
 - Units that the meter reads in
 - Multiplier, if applicable
 - Confirmation that the meter covers whole tenant space

SYSTEM REQUIREMENTS

- **SHUT OFF VALVE** located at eye level in a wall behind a labeled access door is required. Locate in or near employee restroom and/or as designated by Landlord.
- **COPPER** is required for all domestic supply lines and condensate lines.
- **INSULATE** all exposed piping above Tenant's ceiling with minimum of one-half inch (1/2") glass fiber with non-combustible UL rated vapor barrier jacket, insulation shall conform with all fire and smoke ratings per ASTM E84, NFPA 255, UL 723 and Landlord's Insurance Carrier.
- **COLD AND HOT WATER PIPING** shall be type "L" seamless hard-drawn copper tubing above ground and type "K" below ground and be in conformance with ASTM B88-48. Fittings are required to be wrought, suitable for 200 psi. Connections to dissimilar materials shall be made with dielectric unions. Joints shall be 95-5 ton antimony for 200 psi.
- **ELECTRIC WATER HEATERS** are required for domestic hot water.
- **CORE DRILLING**, where permitted, is to be provided by Landlord's designated contractor, at Tenant's expense, per project standards. Coordinate with Landlord representative.
- **NO ROOF WORK** of any kind can be performed prior to onsite meeting with the Landlord's On-Site Representative. Any required roof penetrations shall be performed in coordination with Landlord's roofing contractor, as outlined in HVAC Design and Construction Criteria.
- **ROOF AND SLAB PENETRATIONS** made by Tenant's General Contractor shall conform to Landlord's standard criteria and shall be subject to Landlord's approval as to location and construction details.
- **WEATHERPROOFING** of any roof penetrations required by Tenant shall be performed by Landlord's authorized roofing contractor. Tenant's General Contractor shall pay all such costs, therefore, directly to such roofing contractor upon their demand. Any failure to follow this procedure, and any damages resulting there from, shall be at the Tenant's sole cost and expense.

> PLUMBING > SYSTEM REQUIREMENTS

SYSTEM REQUIREMENTS

- **ALL PIPES PENETRATING AND/OR LOCATED ON THE ROOF** shall be painted to contrast roof color, grey specification to be provided by Landlord (for non-gas piping's only). Use the appropriate coats of pre-treatment primer prior to the final coat. Final coat of the roof matching color shall be approved by Landlord.
- **TENANT'S GENERAL CONTRACTOR SHALL PROVIDE A FIRE WATCH** whenever any welding is done within the Demised Premises. The person performing the fire watch shall remain in the Tenant Space for at least one (1) hour after the completion of any welding.
- **SANITARY VENTS** through the roof shall be a minimum of 4" and extend a minimum of 8" above finish roof. All roof repairs to be by the Landlord's required roofer at Tenant's expense.
- **ABOVE GROUND SANITARY VENTS** (other than food waste) must be service weight BUIIcast iron, with fittings matching the same weight as the pipe.
- **FLOOR DRAINS** are required in the toilet room and in all "wet" areas.
- **WATERPROOFING** must be installed in all "wet areas" such as kitchens, restrooms, mop sinks, drinking fountains, etc. The waterproof membrane must extend 4" vertically on all demising walls. This membrane will be water tested by the General Contractor and inspected and signed off by Mall Personnel. If the membrane fails the water test, it must be replaced.
- **CLEAN OUTS** must terminate flush with the finish floor or wall. No clean outs are permitted above the ceiling. Floor or wall cleanouts must be provided every 50' with ready access.
- **GARBAGE DISPOSALS** are not allowed.
- **HAIR SALONS/PET SHOPS** must provide hair and solids interceptors on all sinks and basins which may receive human or animal hair. After installation, these hair interceptors shall be properly maintained so as to keep the sanitary system free from any adverse conditions. A maintenance contract with Mall-approved vendor is required to be submitted for record with Mall Operations
- **HAIR RECEPTORS** must be installed on all sinks, basins, and special sanitary units which may in any way receive human or animal hair.
- **KITCHEN SINKS** including pot sinks, scullery sinks, pre-wash sinks and other kitchen units must be connected to a grease trap.
- **DISHWASHERS** may not be connected to grease trap.
- **GREASE INTERCEPTOR** must be designed and approved by Landlord prior to installation, especially if located outside the lease line. Traps must be approved by NYC Department of Buildings (NYC DoB) and Sewer Authority.
- **OIL COLLECTION AND HAULING SYSTEM** is required for Tenants with fryers or other grease/oil generating equipment that does not run through an interceptor. Landlord does not provide a centralized collection point.
- **BACKFLOW PREVENTERS** are required for food service, hair salons or other Tenants with equipment or operations that have the possibility of backflow. These must be certified and acceptable to the water district and checked yearly or as required by the local authority having jurisdiction.
- **ADA RESTROOMS** are required in every Tenant space with a minimum of one water closet and one lavatory and in accordance with local code officials and must include a 3" floor drain. Mop sinks and water fountains must be installed per local code requirements. An exception to this requirement is only permitted for Food Court Tenants who are within close proximity to the public restrooms upon approval of the Landlord and local code official.
- **ELECTRIC DOMESTIC HOT-WATER HEATER** supported from the floor or on a platform above the toilet room with an ASME approved temperature and pressure relief valve is required. Discharge from said hot-water heater temperature and pressure relief valve shall be piped to a floor drain. At Tenant's option, instantaneous water heaters may be used. Tenant shall furnish a four-inch (4") high, watertight drip pans under all water heaters (located above the ground floor) with a drain piped to the floor drain. Install vacuum breaker to typical re-link valve piped to floor drain. All piping, clamps, supports, etc., shall be fastened to joists or beams.
- **PLUMBING VENT**, where Landlord has not provided a Tenant connection, Tenant is required to route and/or locate, all toilet vent stacks so that all roof penetrations occur at a minimum of ten feet (10'-0") away from any mechanical equipment intakes or outside air intake hoods, per Landlord's direction.
- **WATERLESS URINALS** are required in tenant restrooms when urinals are used.
- **LOW-FLOW WATER CLOSETS** using 1.6 GPF or less gallons per flush are required where water closets are used.
- **OPERATION SENSORS AND LOW-FLOW HEADS** using 0.5 GPM or less are required if Tenant is installing a Restroom.

GAS SERVICE

Natural gas service is available for food service Tenants from the gas service manifold and meter area located outside the Demised Premises, as selected by Landlord. Tenant shall apply for a Direct Meter from National Grid.

- Tenant shall notify Landlord of such requirement(s) during or prior to the Preliminary Plan submission. If available and approved, Tenant shall indicate on Tenant's final drawings the complete design, including the load calculations of the gas system in the Demised Premises.
- The entire piping system and equipment or fixtures shall be furnished with automatic shut-off devices/controls and color coded or identified as such, as required. Tenant shall arrange with the local utility company for gas service to the Tenant Space, comply with their requirements for metering and service and extend main pipe (properly seized) to the multimeter manifold area (if available) located outside the Demised Premises. The complete routing and installation of the piping shall be at Tenant's sole cost and expense. Landlord reserves the right to deny gas service.
- All gas piping shall be by Tenant and shall be schedule 40 black steel, ASTM A53 with welded or 150 lb. screwed fittings. All valves, fittings and specialties shall conform to governing codes and requirements of the utility company, as it relates to piping and equipment installation and testing methods and procedures.
- Tenant is required to ensure that all slab penetrations within the Tenant Space (and through the roof) are properly sealed and remain watertight to prevent possible water leakage and/or damage, by Landlord's designated contractor at Tenant's expense. Any damage caused from failure to do so shall be at Tenant's sole risk and expense.
- Shut-off valves shall be provided at all connections to fixtures. All underground sanitary and vent piping shall be service-weight cast-iron, with fittings of the same weight as pipe or PVC Schedule 40 may be used in accordance with the requirements of the local authority. All above ground sanitary piping within the demising walls shall only be service-weight cast-iron, with fittings of the same weight as the pipe.
- All materials shall be new and of commercial grade and bare underwriter's label(s), where such labeling applies.

> MECHANICAL > ENVIRONMENTAL

Tenant shall design, furnish and install HVAC, heating and ventilation equipment that shall always serve their Demised Premises. Tenant shall provide and install make-up air, relief air, smoke purge and exhaust system, as required, including balancing and back-draft dampers, fire dampers, curbs, exhaust and intake air hood(s).

GENERAL CRITERIA

Tenants without Landlord granted roof access will be provided with a pathway for Tenants installation of ducted, untempered ventilation (outside) air and ducted exhaust as required. Tenants are not permitted to use a water-cooling tower or any evaporative cooling apparatus.

NOTE: All abandoned MEP equipment within demised tenant space must be completely removed by Tenant.

ENVIRONMENTAL CRITERIA

Tenant is required to design and install an HVAC system to serve the demised Tenant space based upon the following environmental design criteria:

- Cooling – Indoor: 75° F dry bulb (DB) / 50% Relative Humidity (RH)
- Cooling – Outdoor: 94° F dry bulb (DB) / 75° F wet bulb (WB). Apply ASHRAE Fundamentals 1% DB / MCWB data
- Heating – Indoor: 70° F dry bulb (DB) / Relative Humidity (RH) per ASHRAE 55
- Heating – Outdoor: 10° F dry bulb (DB). Apply ASHRAE Fundamentals 99% Winter Heating data

Ventilation (Outdoor Air)

Ventilation air to be provided per the requirements of applicable NYC DoB codes (NYCMC, Table 403.3.) All unique zones, uses, occupancies and equipment with demised tenant area shall be evaluated to provide code compliant ventilation. Ventilation air quantiles shall be identified in a Ventilation Schedule published on the construction documents.

Central Heating & Cooling Infrastructure Characteristics for Tenant Design

Kings Plaza operates a Total Energy Plant (TEP) which utilizes cogeneration principles to provide centralized chilled and heating hot water to some tenants through a 4-pipe distribution piping network. Other Tenants are provided with conditioned through a dedicated supply duct. Tenants are required to provide air handling equipment which utilizes the Landlord's infrastructure.

Design characteristics to be used by Tenants on the chilled water system when selecting equipment are:

- Heating / Cooling Medium: Water (0% Glycol)
- Chilled Water: CHWS: 43°F. / CHWR: 58° F. ($\Delta T = 15^\circ$ F at peak load)
- Heating Hot Water: HWS: 190° F. / HWR: 150° F. ($\Delta T = 40^\circ$ F at peak load)

Heat Transfer Coil Requirements:

- Maximum working pressure of all Tenant heat transfer coils and controls: 125 PSIG
- Maximum allowable pressure drop through all heat transfer coils and controls: 30 f. W.G.
- NOTE: Maximum allowable pressure drops noted is without the use of booster pumps.

Chilled Water & Heating Hot Water Piping Design Requirements:

- Piping shall be sized per requirements of NYC Energy Conservation Code and ASHRAE 90.1, Table 6.5.4.5.

Availability of Services:

- Chilled Water: Available during normal business hours during the cooling season. Cooling season is when outdoor conditions are $\pm 61^\circ$ F. or greater.
- Heating Hot Water: Available during normal business hours during the cooling season. Cooling season is when outdoor conditions are $\pm 60^\circ$ F. or lower.

Design characteristics to be used by Tenants on the conditioned air system are:

- Air temperature is delivered to the space at approximately 60° F.
- Tenants are also provided a hot water line (1 1/4" - 160 °F supply water temp and 50 °F return temperature)
- Tenants are to install a heating coil for heat during the winter months and set a thermostat within the space.
- Tenants are permitted to install a VAV box if desired.
- There is no EMS system to connect into for the conditioned air system.

> GENERAL / HEAT RECOVERY / ROOF EQUIPMENT

GENERAL EQUIPMENT REQUIREMENTS

- Where required and permitted by Landlord, direct expansion air-cooled condensing equipment shall be selected at ARI 95° F ambient outdoor dry bulb design temperature.
- Equipment shall be provided with low ambient control if recommended by unit manufacturer.
- Tenants with spaces greater than 6,000 square feet are required to furnish multiple air handling units to limit the concentration of loads on the structure.
- City of New York and Landlord require that no roof top equipment is visible from public areas. Landlord will determine if screening is required which will be provided by Tenant at Tenant's expense.
- Tenant must submit roof plans, hanger details / structural calculations, framing details and curb/penetration details for all HVAC equipment installations
- All roof cuts required by design must be by Landlord's designated contractor at Tenant's expense.

HEAT RECOVERY EQUIPMENT

- Tenant's condensing unit and/or packaged roof-mounted units shall be located on the roof in areas specifically designated for such equipment. Units shall conform to Landlord's requirements with respect to location, weight, size and service clearances.
- Equipment shall not exceed six feet (6'-0") in height (installed) and shall furnish a minimum twelve-inch (12") clearance from the top of the roof-mounted curb or support platforms to the top finished surface of the roof. Any additional reinforcement of the roof structure necessary to support equipment shall be at Tenant's expense.
- Maximum size of RTU shall be 15 tons on Main Mall and 20 tons on former Sears building. In any given bay there shall not be more than two Tenant RTU's and two Tenant condensing units. No Tenant RTU or condensing units can rest on a joist supporting another Tenant's unit.
- Tenants whose Demised Premises are not located directly under the existing roof areas specifically designated for mechanical equipment, shall use a split type HVAC system. Compressor/ condenser or heat pump shall be located on the roof areas designated for such equipment, and the fan coil section located within the Tenant Space. Tenant shall install interconnecting conduits, wiring, and refrigeration piping.
- All Tenant heating / cooling equipment shall incorporate Total Energy Recovery (e.g. ERV, total enthalpy recovery, sensible / latent energy recovery, etc.) This requirement is mandated by the Landlord and is over and above any minimum requirements set by the applicable codes.

ROOF MOUNTED EQUIPMENT

- All roof-mounted equipment shall be located on curbs flashed to the structural substrate or on raised support platforms. Where practical, all ducts, conduits, drains and refrigerant lines shall penetrate the roof inside the curb support.
- Fabricated support platforms for all roof-mounted equipment shall be sized to span from centerline to centerline of the supports within the structural bay as approved by Landlord. Tenant shall arrange for installation one-half inch (½") thick roof pads around all roof top equipment and connecting to Landlord's service walkway for equipment maintenance.
- All roof work must be completed by Landlord's approved roofing contractor at Tenant's expense. Location of all roof-mounted equipment must be approved by Landlord at Tenant's submittal.
- A visual inspection with Mall Management will be required prior to penetrations as some roof areas may contain high voltage conduit and conductors.
- All remote piping, conduit, control or wiring system penetrating the roof shall utilize a horizontal, capped curb penetration system. Flexible neoprene boots, pitch pockets or other vertical systems are not permitted. All pipe penetration system details must be approved by Landlord prior to installation.
- All RTU units must have condensate trap and extensions fabricated of Type L copper, individually supported on 5'-0" centers which spill to the nearest roof drain. All work to be coordinated with Landlord's designated roofing contractor and mall management.
- All Tenant equipment, ductwork, control dampers, supporting systems and insulation shall be fabricated from materials suitable for long life in exterior applications within this geographic location.
- Tenant's contractor shall remove any HVAC units over the Demised Premise not being used and repair the roof to match adjacent conditions and construction. No curb caps will be permitted.
- All roof penetrations made by Tenant shall be subject to Landlord approval as related to location and construction details. Weatherproofing of all Tenant roof installations shall be performed by Landlord's authorized roofing contractor. Tenant's General Contractor is required to pay all costs directly to such roofing contractor.
- Tenant's General Contractor is required to provide temporary weatherproofing for all roof penetrations until Landlord's roofing contractor has made the final patch.

> GENERAL HVAC / EXHAUST / SMOKE PURGE

GENERAL HVAC

Air handling units, heating equipment, water heaters and other equipment located within the Demised Premises are required to be located over the toilet or storage areas using support systems provided by Tenant. Equipment and supports are not to exceed maximum live loads for structure. Tenant to provide location and mounting details certified by a licensed engineer at time of submittal.

Tenant's HVAC system shall be provided with all necessary controls and devices and be compatible with the Landlord's HVAC system and fire alarm system. All low voltage controls shall be in conduit.

Tenants that have odor producing operations shall install a forced draft ventilation system to maintain a negative pressure within the Tenant Space and discharge into the atmosphere via code approved means that are approved by Landlord. Tenant is responsible for proper diffusion of the exhaust in such a manner as to prevent odors from entering air intakes of other ventilation systems. Tenant shall furnish complete data indicating system air balance in the Demised Premises and a certified third-party balance report no more than thirty (30) days after opening.

HVAC system shall be in operation whenever Landlord-provided HVAC services are operating. Tenants are required to install a DDC system of programmable controls with time-clock functionality for control of their HVAC systems. Life safety alarms shall be connected to the Landlord fire/smoke alarm system.

In accordance with all governing codes, Tenant shall install all condensate drains from air-handling units to flow indirectly (air gap) into Tenant's sanitary line. All condensate lines shall be insulated of Type L copper.

Tenant is required to install all controls and devices required to furnish complete compatibility to the Landlord's fire alarm system. Route piping connections around the air-fan coil unit to permit access for filter changes.

TOILET EXHAUST

Where the Landlord has not provided for an exhaust duct tap, the Tenant shall design and procure and install an active toilet exhaust system, consisting of fan(s), back draft damper(s), ductwork, registers and exhaust louver / hood. System shall be sized for 75 CFM per flushing rim fixture (water closet or urinal), as required to meet code and Tenant's requirements. Such system shall discharge to the atmosphere via the roof, through Landlord approved exterior wall locations, or into Landlord provided exhaust ducts where applicable.

No exhaust(s) or vent(s) can be located within a minimum of 10 feet (10'-0") of any supply or air intakes.

POST FIRE SMOKE PURGE EXHAUST

NYC Building Code requires a Post Fire Smoke Purge System be provided for all occupied areas. Most Tenants with access only from the Main Mall Common area will be included in the Mall's common smoke exhaust. Tenants over 1500 square feet are to verify with Tenant Coordination if supplemental Post Fire Smoke Purge is required.

Tenants needing Post Smoke Purge Exhaust shall be required to furnish a rooftop mounted smoke exhaust fan as part of their Tenant improvements to meet the requirements of the code. Tenant Engineer shall be responsible for the sizing of the smoke purge exhaust fan in accordance with applicable codes and AHJ requirements. Exhaust volume shall not be less than one (1) cfm per square foot or six (6) air changes per hour, whichever is greater.

Tenant space area and volume used to calculate the exhaust volume, shall be measured from the front to rear of the store, including all storage/stockroom(s), the full width of the space and from the finished floor to the underside of permanent structure, (roof, mezzanine, etc.) above (even when ceilings are provided in the Tenant Space).

The sequence of operation of the Tenant's HVAC system and smoke exhaust fan, during an emergency, shall be in accordance with the smoke control system requirements, as stipulated in the latest adopted NYC Building Code (including applicable amendments) and the requirements of this Tenant Handbook, Smoke/Fire Alarm Design and Construction Criteria.

> DUCTWORK / FOOD SERVICE

DUCT WORK

Hanger-wires, duct-straps, fastening devices, etc. shall be fastened to top chord of joists and/or beams above and conform to the Mechanical Code of the State of New York. Tenants may not attach anything directly to the upper level slab or the roof deck.

All ductwork shall be fabricated from galvanized sheet metal, stainless steel or black steel in accordance with the standards of American Society of Heating, Refrigeration and Air Conditioning Engineers (ASHRAE), and Sheet Metal and Air Conditioning Contractors National Association (SMACNA) for low pressure, low velocity ductwork. Flexible metal ductwork shall be allowed only in branch ducts, in a length not to be more than six feet (6'-0"). Plastic liner ductwork with internal wire reinforcement is not permitted.

Tenant is required to specify the type of duct and duct insulation used, as per NFPA, SMANCA and applicable standards and Landlord's insurance carrier's requirements. All ductwork systems shall be designated as low velocity (under 2,500 fpm) and low pressure (under 2" water gauge).

Branches from main low-velocity trunk ductwork shall be furnished with splitters, dampers or similar balancing devices in accordance with the standards of the Associated Air Balance Council. Fire dampers shall be provided, as required. Supply and return ductwork shall be insulated with a minimum of two inch (2") thick 3/4lb thick blanket-type insulation with a vapor barrier. All ductwork new or existing which passes through the space must be fitted with appropriately rated fire dampers when passing through fire rated partitions.

Acoustical liner may be furnished, as required per NFPA standards, Landlord's insurance carrier's requirements, and be UL rated. Flame spread rating shall not be more than twenty-five (25) and smoke developed rating shall not exceed fifty (50). Air distribution supply registers and/or diffusers shall be designed and specified for 50 fpm terminal velocity.

The entire installation is required to be performed by a licensed HVAC contractor in a first-class, workman-like manner.

All material shall be new and of commercial grade, and bear an underwriter's label, where such labeling is applicable.

FOOD SERVICE TENANTS

All the items indicated with the General Requirements apply with the following additional criteria:

- The Tenant shall review and comply with NFPA #96 and related codes and standards concerning cooking exhaust system requirements.
- All roof-mounted kitchen exhaust fans that handle a grease discharge shall be provided with an integral grease collector assembly and grease drain. Roofing protection and grease containment pads are required to be installed around the perimeter of each Tenants smoke/grease exhaust stack. The grease drain shall be emptied via a drain line to the Tenant's grease waste line and connected to a point prior to that line entering the grease receptor.

- Tenants who specify the use of a rooftop centrifugal exhauster for their cooking facilities shall furnish proper clearance between the exhauster and the roof.
- All cooking exhaust ducts shall be seamless and welded of at least sixteen (16) gage. Slope all ductwork at minimum of 2% (1/4" per foot) towards hood. Provide intermediate grease sumps and drains as required.
 - Grease ducts with cross section \leq 155 square inches = 16 gage steel
 - Grease ducts with cross section $>$ 155 square inches but $<$ 200 square inches = 14 gage steel
 - Grease ducts with cross section $>$ 200 square inches = 12 gage steel
- Range exhaust hoods shall be fabricated in accordance with all codes and shall be at least sixteen (16) gauge, or heavier, black steel, with all joints welded.
- Access doors shall be provided and be in the vertical face of the horizontal run, at the bottom of the vertical riser and/or as required by code.
- Provide automatic and manual devices for shutting down fuel or power supply.
- Kitchen range hood exhaust ducts shall be insulated with zero clearance, ceramic, 2-hour fire-rated insulation or installed in a 2-hour rated chase per applicable codes, and Landlord's insurance carrier's requirements at the actual in-use temperature design. Tenant shall furnish complete specifications of type of insulation on their submittal drawings.
- Hoods and exhaust systems for food processing shall be protected by a fire extinguishing system, installed in accordance with all the requirements of the jurisdictional authorities and Landlord's insurance carrier. All systems shall be furnished with access panels, as required.
- Make-up air systems are required for all exhaust systems designed for a minimum of eighty percent (80%) of all exhausted air quantity. The exhaust and make-up air systems shall be electrically interlocked for simultaneous operation of both exhaust and make-up.
- Exhaust hoods shall be fabricated in accordance with all codes and shall be at least sixteen (16) - gauge or heavier stainless steel, with all joints welded.
- Tenant shall be responsible for installing grease traps for its premises in accordance with all local requirements and codes per the NYC Building Code. Existing to be field verified. All costs at Tenant's expense.
- Prior to the use or concealment of any portion of a grease duct system, a leakage test shall be performed. Ducts shall be concealed where installed in shafts or covered by coatings or wraps that prevent the ductwork from being visually inspected on all sides. The duct installer shall be responsible for providing the necessary equipment and performing the grease duct leakage test. A duct leakage test, in accordance with this section, shall be performed for the entire duct system, including the hood to duct connection. All tests must be performed in the presence of the Special Inspector.

> NOISE / VIBRATION

NOISE LEVEL LIMITS

Any Tenant whose operations generate sound that would disturb or affect neighboring tenants is required to limit noise transmission from their space.

Tenant is responsible for isolation of all equipment so that vibrations and noises are not transmitted. Any noise deemed objectionable Landlord's Site Representative shall be corrected at Tenant's expense.

The source of sound may include but not be limited to patrons, background music, activity levels, Tenant's HVAC system or equipment noise and/or vibration, and food preparation.

In the event that the maximum Sound Pressure Level values are exceeded, the Tenant shall propose noise mitigation measures that may include but not be limited to: a suspended acoustical or gypsum board ceiling on vibration isolation hangers; sound attenuators at return air openings in the event that the space above the suspended ceiling functions as a return air plenum; sound attenuation glass fiber bats in the ceiling cavity.

If the Tenant's operation includes loud back-ground music or noisy food preparation or other major noise producing activity or equipment, Tenant shall engage a professional acoustical consultant to provide the following information:

- A listing and location of the major noise or vibration sources within and at the limits of their demised space along with measured values for each element.
- A noise and vibration mitigation plan for each of the noise/ vibration sources.
- The acoustical consultant shall be a member of one or more of the following: National Council of Acoustical Consultants; Institute of Noise Control Engineers; Acoustical Society of America. The Tenant shall provide a written report, prior to construction, for review by the Landlord containing the following Information:
- A summary of the acoustical consultant's analysis and calculations.
- Recommended noise mitigation measures, if required.

VIBRATION MITIGATION

Tenant shall provide the following vibration isolation of suspended equipment, piping and ductwork:

- Fan coil units, makeup air or exhaust air fans hung from structure above: Vibration isolation hangers equal to Mason Industries Type 30. Provide minimum 1.0" static deflection springs for equipment less than 5 hp. And 1.5" deflection springs for equipment 5 hp. and above.
- HVAC and plumbing piping; Vibration hangers equal to Mason Industries Type HD with a minimum static deflection of 0.2".
- A.C. Units or fans on roof above: Package rooftop units shall include a prefabricated isolation roof curb by the unit manufacturer. Condensing units for split system or fans shall be isolated using neoprene pad isolators in between unit and rooftop support system.
- All ductwork, piping and equipment shall be supported per SMACNA and applicable codes.

> STRUCTURAL

DEMOLITION AND RENOVATION

Any existing materials or equipment not to be reused must be completely removed and disposed of properly including all materials and equipment above the ceiling line that is not part of Landlord base building architecture, structural or MEP systems. Repairs required to roofing systems or other parts of the Center must be completed to Landlord's specifications, using Landlord's designated roofer, at Tenant's cost. Penetrations that are not to be reused shall be repaired to match existing surfaces and brought to original roofing condition. No curb cap permitted.

ROOF PENETRATIONS

Roof Penetrations may not be made unless Mall Management has reviewed and approved area with a visual inspection. Roof has high voltage wiring in certain locations. When mounting roof top units use Mall typical roof top curb details.

Do not shoot or drill into roof deck from second floor space until Mall Management has reviewed and approved.

- First floor to underside of deck – 17'-6"
- Second floor deck height – 15'-6"

STRUCTURAL MODIFICATIONS

The Tenant shall be responsible for all costs associated with any modifications of, or connections to, the Base Building structural system. Additionally, the Tenant shall be responsible for costs associated with the disruption of the operations of adjacent Tenants. Structural modifications must be performed and tested by the Landlord's designated contractors at Tenant's expense. Any attachments to, or modifications of, the building's structural systems must be approved by the Landlord's Engineer. Review of proposed structural modifications by Landlord's Structural Engineer shall be at Tenant's expense.

Proposed modifications to the base building and structural work of any kind shall be designed, sealed and signed by Professional Structural Engineer licensed to practice in the state of New York. Tenant shall notify the Landlord in writing of any loads in excess of Landlord's design. Additional structural reinforcement shall be provided for all roof openings and equipment by the Tenant's GC at Tenant's expense. Structural dowels/mesh/welding as per code for all trenching concrete pour backs.

Do not shoot screw drill or weld to Landlord's second floor deck or structure. Use nested studs, cleats, clamps or through bolts as attachment methods.

All structural work must be inspected by a Borough of Brooklyn approved and licensed inspection company. A list of approved inspection companies may be obtained by contacting the Borough of Brooklyn Building Department.

FLOOR SLABS AND PENETRATIONS

All floor penetrations through structural concrete slabs must be core-bored or saw-cut, sleeved, sealed, fire stopped and waterproofed. All piping sleeves shall extend a minimum of four inches in height or equal to the height of the base. Provide temporary protection until construction is complete. All core drilling and Landlord approved trenching, where permitted, is to be done by Landlord's designated contractor at Tenant's expense.

Structure must be x-rayed, and field verified with mall management prior to any penetrations. Any trenching of first floor structurally supported concrete slab shall be designed by a licensed New York P.E. utilizing Landlord recommended details.

Concrete floor slabs are provided by landlord as part of base building construction in AS IS condition. All preparation to receive Tenant finishes is to be by the Tenant. When applicable proper landlord approved expansion joint flooring detail to be followed.

CONSTRUCTION RATINGS

Where a Tenant abuts and exit corridor or exit passageway, Tenant shall install one layer of 5/8" fire rated gypsum wall board in accordance with UL Design specifications.

The Tenant demising wall separating Tenant spaces shall be of a 1-hour fire resistive rating. All metal stud demising walls shall be finished with one layer of 5/8" fire rated gypsum wallboard in accordance with UL Design acceptable construction. Bat sound installation will be required for all new demising walls as per UL Design specifications.

Structured floor assemblies require a 2-hour fire resistance assembly.

The columns of the primary structure shall have a 3-hour spray on rating. Any additional structural columns necessitated by Tenant Work shall require a 3-hour fire resistance rated assembly.

The fire rating on all structural members shall be maintained and repaired by Tenant as required, if damaged. The fire protection provided for any structural component shall not be compromised in any manner by the Tenant.

BROADCAST DATA COMMUNICATIONS

Individual installations of satellite dishes or antenna installations will be allowed with prior approval from the Landlord and installation is coordinated as per mall management specifications.

FOOD CRITERIA CONTENT OVERVIEW

2.1

INLINE COUNTER SERVICE

DETAILS SPECIFIC DESIGN, SIGNAGE, AND TECHNICAL REQUIREMENTS FOR FOOD TENANTS WITH COMMON AREA FACING COUNTER SERVICE AND LIMITED OR NO SEATING.

2.2

RESTAURANTS

DETAILS SPECIFIC DESIGN, SIGNAGE, AND TECHNICAL REQUIREMENTS FOR FOOD TENANTS WITH INTERIOR OR EXTERIOR FACING RESTAURANT SERVICE.

This Food Tenant Criteria is specifically tailored to highlight unique technical and design requirements for Tenant’s cooking, preparing, and selling food products.

Through the application of the Criteria guidelines, Food Tenants will produce distinctly original designs unique to their brand and the Center. These guidelines are to help maintain a consistent design quality while still allowing each Tenant to achieve a high level of expression and diversity.

The goal is to enhance the shopping experience for our Customer through the quality and artfulness of Tenant design.

This Criteria will often point to the [INLINE RETAIL CRITERIA](#), as several requirements and design concepts are shared.

The Tenant’s Architect is encouraged to contact the Landlord’s Tenant Coordinator to discuss any specific design intentions prior to commencing design work. The Tenant Coordinator will strive to resolve all outstanding design issues. However, the Tenant Coordinator may, in the best interest of the Center, reject any aspect of the Tenant’s design.

If an acceptable design cannot be agreed upon, the Landlord may, at the Tenant’s expense, provide an additional concept Storefront design for consideration.

SECTIONS OF INTEREST

- INLINE CRITERIA**
Standard design, technical, and sign requirements in addition to the contents in this section.
- DESIGN INSPIRATION**
Provides design inspirations for visual aesthetics.
- BUILDING DETAILS**
Includes property reference photos and specific Storefront design details.
- PROPERTY INFO**
Includes information on the Property’s building codes, area permitting, and required contractors.
- SUBMITTALS**
Outlines requirements on how and what to compile for submittals to the Landlord for design reviews.



INLINE COUNTER SERVICE > CONTENTS

❑ DESIGN

- ❑ *PREP & FOOD DISPLAY / LAYOUT*
- ❑ *QUEUE / PATIOS / SEATING*
- ❑ *COUNTER DESIGN / COUNTER ELEMENTS*
- ❑ *MATERIALS / LIGHTING / FLOORING*

❑ SIGNAGE

- ❑ *PRIMARY SIGNAGE / MENU BOARDS*

❑ TECHNICAL

SECTIONS OF INTEREST

- ❑ *INLINE CRITERIA*
Includes standard design, technical, and sign requirements in addition to the contents in this section.
- ❑ *DESIGN INSPIRATION*
Provides design inspirations for visual aesthetics.
- ❑ *BUILDING DETAILS*
Includes property reference photos and specific storefront design details.
- ❑ *PROPERTY INFO*
Includes information on the Property's building codes, area permitting, and required contractors.
- ❑ *SUBMITTALS*
Outlines requirements on how and what to compile for submittals to the Landlord for design reviews.

The Inline Food Counter Service Criteria provides key technical information and design requirements to ensure your common area facing counter food service enlivens the consumer experience and interfaces with the Center.

This criteria will often point to the [INLINE RETAIL CRITERIA](#) as several requirements and design concepts are shared. The content in this section highlights the unique concepts for food service design.

The tenant and the tenant's architect assume the following important obligations:

- Fulfill the intent of the Criteria both in concept and in detail.
- Determine and respond to the actual physical conditions of the Tenant's location.
- Maintain and enhance the high standards of quality established in the construction of the Center.
- Ensure the quality of execution of all design material, finish, and detail concepts in the construction of the Tenant's improvement.
- Provide the required detail at all transitions from Tenant storefront to neighboring storefronts, as well as to the base building.



> DESIGN > PREP & FOOD DISPLAY / LAYOUT

Inline and Restaurant Food Tenants must adhere to the design requirements found in the [INLINE RETAIL DESIGN CRITERIA](#).

In addition to the requirements detailed in the Design Criteria, Tenants serving food in their space must adhere to the following design requirements:

PREPARATION AS THEATER

Tenant's offering a peek into the making of food, by nature, include the Customer and make for an authentic experience. This inclusion of the Customer will increase engagement and is highly encouraged.

FOOD DISPLAY

When displaying food, the following requirements must be followed:

- Showcases must reinforce the Tenant's image and be an integral part of the design within the counter.
- Glass must be tempered or a safety type. Plexiglas is not permitted.
- Showcases shall not exceed 14" above counter and 36" overall width. It shall not be more than 50% of the counter length and located no closer than 48" from the neutral pier.

LAYOUT

Due to the high visibility of the Customer Service Area particular attention is given to the design review of this area. Service areas, furnishings, display cookery, food prep and cooking areas visible from the mall common area must meet strict design standards.

- Support rooms and storage shall be concealed from public view.
- A full-height partition wall must separate the Customer Service Area and Prep Area.
- Access to the Prep Area shall be via a self-closing door or between staggered "blind walls".



> DESIGN > QUEUE / PATIOS / SEATING

QUEUE AREAS

All food venues must provide a queue layout that allows for the Mall to maintain its code minimum distances for general circulation.

Stanchions are not allowed. Other indicators for customer directional flow will be considered.

PATIO AREAS

Exposed patios are encouraged however, they should not extend beyond the lease line. In special cases there may be opportunity to extend the patio but it must be in compliance with all common mall code, circulation requirements, and leasing agreements.

Projection or canopy may increase the visibility of the storefront over seating areas. They also help with lighting the Storefront.

- Common mall flooring must be maintained. Coordinate with Landlord design if railings or other elements will have an effect on the flooring.

SEATING

Where interior seating is needed or desired, it is suggested that the enclosure line be moved into the lease space by approximately 12 feet.

- Patio seating must be separated from the common area circulation in the Mall. A layout will be required.
- All visible furniture must be reviewed by the Landlord for suitability both aesthetically, as well as for performance specifications.
- Tenant is responsible to confirm additional requirements with the local authorities for any railing or barrier for the Tenant's proposed area.
- In some cases options for furniture may be supplied by the mall design team for the Tenant to choose from.



> COUNTER DESIGN / COUNTER ELEMENTS

FRONT SERVICE COUNTER DESIGN

- The form and materials used for counters shall be designed to be inviting to the public to help lure them to the space.
- Tenant to specify a protective edge at the bottom of the counter.
- Counter tops must be “Corian” or similar solid surface materials, metal or stone. Tenant counter and counter tops are to be custom designed and fabricated.
- Plastic laminated countertops are prohibited.
- Maximum counter height is 3’-6”. Counter design, including heights, must comply with all accessibility guidelines enforced by national or local jurisdictions and the Americans with Disabilities Act.
- Sneeze guards shall be used above the front counters as required.

COUNTERTOP ELEMENTS

- Cash registers must be recessed so that they extend no more than 9” above the counter top.
- Condiment and utensil displays or dispensers must be fully recessed into the counter.
- Fully recessed counter-top trash receptacles (for straw wrappers, etc.) must be provided near the condiment and utensil displays.
- Drink dispenser and other utilitarian kitchen equipment may not be placed on the front counter.



> MATERIALS / LIGHTING / FLOORING

FRONT SERVICE COUNTER AND STOREFRONT MATERIALS

- All finish materials must be backed by a minimum 5/8" solid surface material and may include the following:
 - Countertops must be solid surface materials, metal or stone. Tenant counter and counter tops are to be custom designed and fabricated.
 - All stone/tile colors must be integral throughout.
 - Metal panels and architectural hardware shall have a professional and durable finish.
 - Color anodized, baked painted or antique finish
 - Wood veneers and weathered or distressed wood (submit specification for approval)
 - Resin panels such as 3-Form products
 - Back-painted tempered glass panels
 - Glass tiles
- Finish materials shall NOT include the following materials:
 - 4"x4", 6"x6", 12"x12" tiles
 - Shingles or boards
 - Plastic laminate
 - Faux or plastic formed brick, block or stone
 - Clear anodized aluminum
 - Other materials as deemed unacceptable by Landlord.

LIGHTING

- Tenants must light both their Storefront as well as the countertop. Lighting on architectural elements and menu boards are required.

FLOORING

- All "wet" areas must install a waterproof membrane that is tested and confirmed by the Landlord. Full requirements can be found in the plumbing section of the [INLINE TECHNICAL CRITERIA](#).



> SIGNAGE > PRIMARY / MENU BOARDS

PRIMARY STOREFRONT SIGN

Inline and Restaurant Food Tenants must adhere to the signage requirements found in the [INLINE SIGN CRITERIA](#).

MENU BOARDS

Menu board applications must be a part of the overall store design. We strongly encourage using a graphic designer to create your boards.

DESIGN REQUIREMENTS

The following requirements must be used when designing your menu boards:

- All menu boards must be submitted to the Landlord for review and approval prior to start of Tenant construction.
- Professional quality drawings/renderings must be submitted for approval.
- Design shall be an integral part of the graphics and complimentary to primary signage character.
- Overall width of menu board cannot exceed 60% of overall Storefront width.
- Mounting height to be a minimum of 7'-0" to bottom of sign with maximum height of 10'-0" and held a minimum of 10" from edge of walls.
- The menu board must be non-reflective to avoid glare.

PERMITTED ELEMENTS

Permitted menu board design elements include:

- Artisan type quality such as chalkboards, painted wood or unusual materials and combinations of material.
- Frames, holders, text, photo displays, lighting and materials must be creatively designed.
- High quality digital printouts for menu board may be approved at Landlord's discretion.
 - Photographs used in menu boards must be professionally produced and approved by the Landlord.
 - Plasma screens cannot be surface mounted.
- Externally illuminated menu boards are allowed.
 - Tenant is required to submit light fixture cut sheet for approval.

PROHIBITED ELEMENTS

Not permitted menu board design elements include:

- Standard factory designs.
- Standard surface-mounted box-type internally illuminated menu boards are not permitted.



> TECHNICAL

Inline and Restaurant Food Tenants must adhere to the technical requirements found in the [INLINE TECHNICAL CRITERIA](#).

In addition to the requirements detailed in the Technical Criteria, Tenants cooking food in their space must adhere to the following:

GENERAL REQUIREMENTS

- **KITCHEN SINKS** including pot sinks, scullery sinks, pre-wash sinks and other kitchen units must be connected to a grease trap.
- **DISHWASHERS** may not be connected to grease trap.
- **GREASE INTERCEPTOR** must be designed and approved by Landlord prior to installation, especially if located outside the lease line.
- **OIL COLLECTION AND HAULING SYSTEM** is required for Tenants with fryers or other grease/oil generating equipment that does not run through an interceptor. Landlord does not provide a centralized collection point.
- **BACKFLOW PREVENTERS** are required for food service, hair salons or other Tenants with equipment or operations that have the possibility of backflow. These must be certified and acceptable to the water district and checked yearly or as required by the local authority having jurisdiction.

KITCHEN EXHAUST REQUIREMENTS

- **LANDLORD REVIEW** is required to ensure the exhaust does not compromise the ventilation air of adjacent mall roof top units.
- **EXHAUST FAN** must be a SWSI centrifugal fan which must be fitted with a minimum 10'-0" stainless steel upblast. Guy wires must be attached to the roof in order to secure the stack. Use the mall roofer for connection of the guy wires at Tenant's expense.
- **GREASE GUARD CONTAINMENT SYSTEM** (or approved equal) must be installed to protect the Landlord's roof. A quarterly maintenance program must be in-place for the grease containment units. Proof of the maintenance contract must be presented to Operations Manager prior to the store opening.

RESTAURANT SPECIFIC REQUIREMENTS

- **PLANS MUST SHOW** sizes and locations for all duct and piping through roof as well as all required fireproofing.
- **CONTAIN ALL GARBAGE AND REFUSE AREAS WASH DOWN** "grey" water and properly drain off into city approved system (i.e. sewer or storm).

FOOD PREP AND BAKING ON SITE REQUIREMENTS

- **INSTALL DRY CHEMICAL EXTINGUISHING DEVICES** (such as Ansul) approved by the fire insurance rating organization carriers.
- **MAINTAIN ALL EXHAUST DUCTS AND FILTERS** in a clean condition. Ducts are to be professionally cleaned on a regular basis to help prevent grease fires.
- **GARBAGE AND REFUSE MUST BE PLACED IN CONTAINERS** which shall be kept, until collected, in a self-contained area within the demised premises set aside for the storage of garbage and/or storing of inflammable or combustible materials. Tenant agrees to install and maintain appropriate chemical extinguishing devices.
- **FAILURE TO INSTALL REQUIRED EQUIPMENT** referred to in this section and/or to subscribe to the servicing thereof, Landlord shall have the right to enter the demised premises and to make any necessary installations and charge the cost of such installations and/or the servicing thereof to Tenant which Tenant agrees to pay to Landlord, as additional rent, within ten (10) days after demand.

GAS UTILITY

Natural Gas service is available for Tenants to obtain. Tenants will be responsible for obtaining gas service from the gas company. Gas is permitted for cooking equipment only, not for HVAC.

SPRINKLER

All walk-in coolers/freezers shall be supplied with non-freezing sprinklers.

- Demised Premises with exhaust hoods, grilles and/or cooking facilities shall be equipped with a fire extinguishing system, including an alarm system. Furnish specific details on the sprinkler plans.
- Upon activation of this system all cooking equipment is required to shut down automatically.
- Connected to Landlord's Fire Alarm System at Tenant's expense.

FIRE ALARM

Heat detectors may be utilized in place of smoke detectors in the Food Tenant Demised Premises.

- An evaluation conducted by a NICET Level IV Fire Alarm Senior Engineering Technician shall investigate potential sources of ambient smoke, moisture, dust or fumes to determine if heat detectors should be installed rather than smoke detectors to minimize nuisance alarms in such areas.
- The intent to install heat detectors rather than smoke detectors shall be submitted to and approved by the FDNY.

RESTAURANTS > CONTENTS

- DESIGN**
 - STOREFRONT / PREPARATION AS THEATER*
 - CONTROL AREAS / SEATING*
 - EXTERIOR*

- SIGNAGE**
 - STOREFRONT / MENU BOARDS*

- TECHNICAL**

SECTIONS OF INTEREST

- INLINE CRITERIA**

Includes standard design, technical, and sign requirements in addition to the contents in this section.
- DESIGN INSPIRATION**

Provides design inspirations for visual aesthetics.
- BUILDING DETAILS**

Includes Property reference photos and specific Storefront design details.
- PROPERTY INFO**

Includes information on the Property's building codes, area permitting, and required contractors.
- SUBMITTALS**

Outlines requirements on how and what to compile for submittals to the Landlord for design reviews.

The Restaurant Criteria provides key technical information and design requirements to ensure your interior or exterior facing restaurant food service enlivens the consumer experience and interfaces with the Center.

This Criteria will often point to the [INLINE RETAIL CRITERIA](#) as several requirements and design concepts are shared. The content in this section highlights the unique concepts for food service design.

The Tenant and the Tenant's architect assume the following important obligations:

- Fulfill the intent of the Criteria both in concept and in detail.
- Determine and respond to the actual physical conditions of the Tenant's location.
- Maintain and enhance the high standards of quality established in the construction of the Center.
- Ensure the quality of execution of all design material, finish, and detail concepts in the construction of the Tenant's improvement.
- Provide the required detail at all transitions from Tenant Storefront to neighboring Storefronts, as well as to the base building.



> DESIGN > STOREFRONT / PREPARATION AS THEATER

Restaurant Food Tenants must adhere to the design requirements found in the [INLINE DESIGN CRITERIA](#).

In addition, Tenants serving food in their space must also adhere to the following:

GENERAL STOREFRONT AND DESIGN

We encourage a cohesive presentation of the brand within the context of the whole Mall design, while the individual brand is important and the two must harmonize. Design should be tailored to its location both within the community and the whole Center's aesthetics.

Restaurants may face both the interior and the exterior, and are often located adjacent to a Mall entry. The exterior and the interior are subject to different Criteria standards, both for presentation and signage.

Interior restaurants oftentimes have a waiting area within the common space. If needed these must be shown in the submissions and be approved by Landlord. They must be coordinated with common area needs and code requirements.

PREPARATION AS THEATER

Tenant's offering a peek into the making of food, by nature, include the Customer and make for an authentic experience. This inclusion of the Customer will increase engagement and is highly encouraged.



> CONTROL AREAS / SEATING

CONTROL AREAS

The DCA is the area at the front of the Tenant space that extends from the lease line to all points 6'-0" into the space. It should convey excitement and give the consumer a reason to engage.

Exposed patios are encouraged however, they should not extend beyond the lease line. In special cases there may be opportunity to extend the patio but it must be in compliance with all common Mall code and circulation requirements.

Projection or canopies may increase the visibility of the Storefront over seating areas. They also help with lighting the Storefront.

In addition to the general DCA Criteria for inline stores the following requirements must be met:

- All patio rails, reception podiums, waiting areas, menu presentations, lighting, heating, visible banquet detailing, and material palates must be presented for review and approval.
- Common Mall flooring must be maintained. Coordinate with Landlord design if railings or other elements will have an effect on the flooring.

SEATING

Where interior seating is needed or desired, it is suggested that the enclosure line be moved into the lease space by approximately twelve (12') feet.

Seating design requirements include:

- Patio seating must be separated from the common area circulation in the Mall by a low barrier. A layout will be required for review.
- All visible furniture must be reviewed by the Landlord for suitability both aesthetically, as well as for performance specifications.
- Tenant is responsible to confirm additional requirements with the local authorities for any railing or barrier for the Tenant's proposed area.



> EXTERIOR

Restaurants with exterior Storefronts will be subject to the general Criteria in this manual, for aesthetics.

Exterior design should be tailored to its location both within the community as well as the whole Mall and its aesthetics.

SITE PLANS

- A Site Plan must be submitted that includes all required calculations for GLA, GBA, and parking requirements.
- Site Circulation must be included showing the adjacent intersections, driveways, drive directions, and dimensions of all access points.
- Photos of adjacent and onsite conditions may be required by Ownership for the review process.

AMENITIES

- Planters, heat lamps, tables, chairs etc., must be submitted for approval. All amenities must be commercial grade and suitable for outdoor use.
- Pendant or sconce lighting must be submitted for approval by Landlord.
 - Lighting plans of canopies and trellis are available in Landlord supplied base drawings.
- Umbrellas are only allowed in the designated areas and cannot overhang into the public right-of-way.
 - Umbrellas should be small in scale (maximum 6'-0" in diameter) and no more than 9'-0" high at the peak.
 - Wood or metal are the only acceptable materials for the umbrella structure. No insignia, graphics or text are permitted on the umbrella fabric.
 - The umbrella fabric must be flame retardant material in a color approved by Landlord's Tenant Coordinator.

EXTERIOR PATIOS

- Any changes to an existing patio must be approved by Landlord. Tenant is responsible to confirm the requirements with the local municipality for proposed use.
- Temporary elements such as greeting stands, or waiting areas must be submitted for review.
- Confirm code height and density of railings for any necessary barriers.
- Patio layouts with adjacent circulation dimensions must be included in the first submittal of documents for design review.
- Railing design details should be submitted with the concept and construction packages for approval by the Landlord design team.



> SIGNAGE > PRIMARY / MENU BOARDS

PRIMARY STOREFRONT SIGN

Inline and Restaurant Food Tenants must adhere to the Signage requirements found in the [INLINE SIGN CRITERIA](#).

Exterior signage must adhere to the requirements established by the local municipality.

MENU BOARDS

Inline and Restaurant Food Tenants must adhere to the menu board requirements found in the [INLINE FOOD SIGN CRITERIA](#).





> TECHNICAL

Inline and Restaurant Food Tenants must adhere to the technical requirements found in the [INLINE TECHNICAL CRITERIA](#).

In addition to the requirements detailed in the Technical Criteria, Tenants cooking food in their space must adhere to the same requirements found in the [INLINE FOOD TECHNICAL CRITERIA](#).

KIOSK CRITERIA CONTENT OVERVIEW

3.1

DESIGN INSPIRATION

PROVIDES DESIGN INSPIRATIONS AS TO WHAT KIND OF KIOSK DESIGNS CAN BE PRODUCED.

3.2

DESIGN ELEMENTS AND REQUIREMENTS

DETAILS DESIGN CONCEPTS AND REQUIREMENTS TO INCORPORATE INTO THE OVERALL KIOSK DESIGN.

3.3

FOOD DESIGN ELEMENTS AND REQUIREMENTS

DETAILS SPECIFIC DESIGN ELEMENTS AND REQUIREMENTS FOR KIOSKS SELLING AND COOKING FOOD.

3.4

TECHNICAL

DETAILS THE TECHNICAL DESIGN REQUIREMENTS TO INSURE THE KIOSK INSTALLATION INTERFACES WITH THE UTILITIES AT THE CENTER.

3.5

PROCESS

PROVIDES AN OVERVIEW OF THE DESIGN, CONSTRUCTION, AND INSTALLATION OF KIOSKS.

3.6

DESIGN DETAILS

SPECIFIC DESIGN DETAILS REQUIRED TO BE ADOPTED AND SHOWN IN THE KIOSK DESIGN SUBMITTAL DRAWINGS.

SECTIONS OF INTEREST

- DESIGN INSPIRATION*
Provides visual inspirations for design aesthetics.
- PROPERTY INFO*
Includes information on the Property's building codes, area permitting, and required contractors.
- SUBMITTALS*
Outlines the requirements on how and what to compile for submittals to the Landlord for design reviews.

Macerich strives to differentiate its shopping environment through fresh, innovative design and unique retail offerings. We transform everyday shopping into a truly unexpected and exhilarating experience.

Innovative design has proven to stimulate customer interest which in turn drives sales. For Macerich and kiosk Tenants to achieve this goal, we ask our tenants to fabricate a high quality, experiential retail design that is cohesive and complimentary to the overall shopping center environment.



DESIGN INSPIRATION > CONTENTS

- URBAN
- ARTISAN
- WHIMSICAL
- INVITING
- ARTSY
- THEATRICAL

SECTIONS OF INTEREST

The following sections provide additional details and requirements related to this Criteria:

- DESIGN INSPIRATION*
Provides additional visual inspirations for design aesthetics.

GET INSPIRED!

The following inspirations are intended to help you visualize what kind of kiosk design can be produced. These aesthetic examples encourage bold design to draw Customers and enliven the common area visuals of the Center. By the nature of their prominent locations, kiosks require great design and an attention to detail to ensure high quality retail experiences.



> URBAN

URBAN

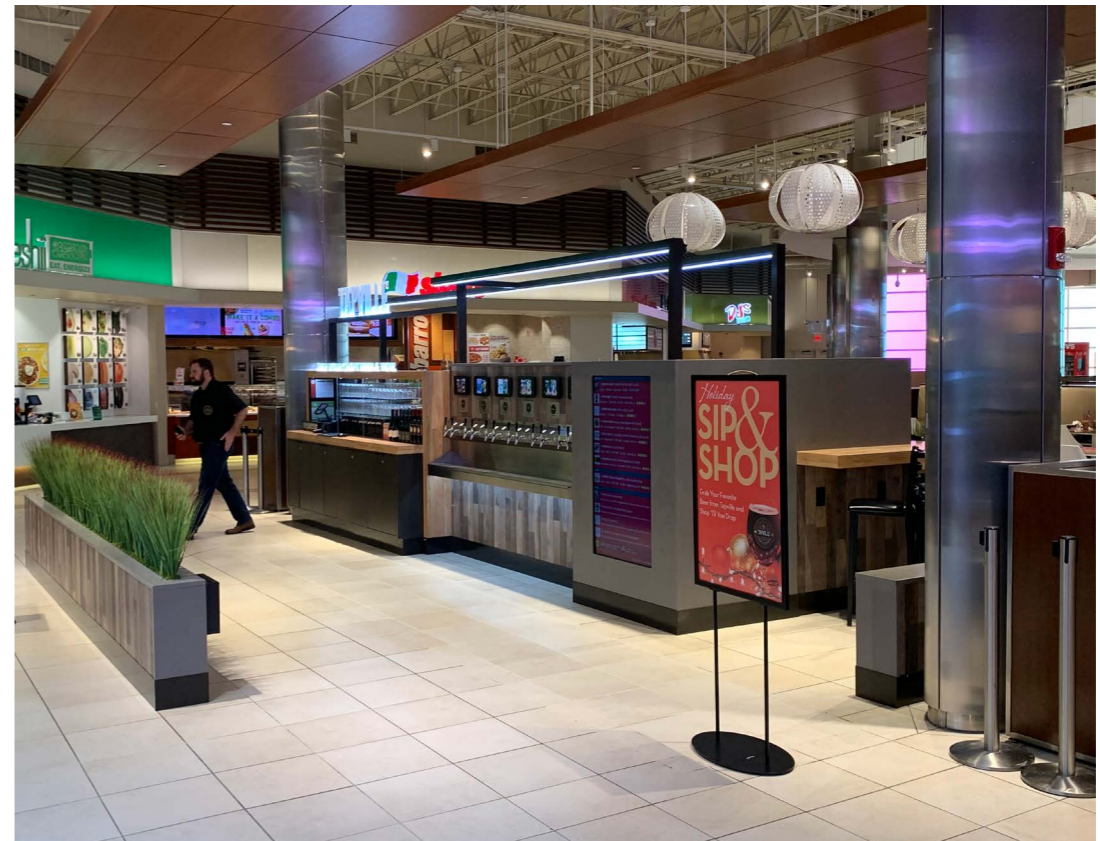

EDGY, FUNKY, STREET SAVVY STYLE, INDUSTRIAL

> ARTISAN

ARTISAN

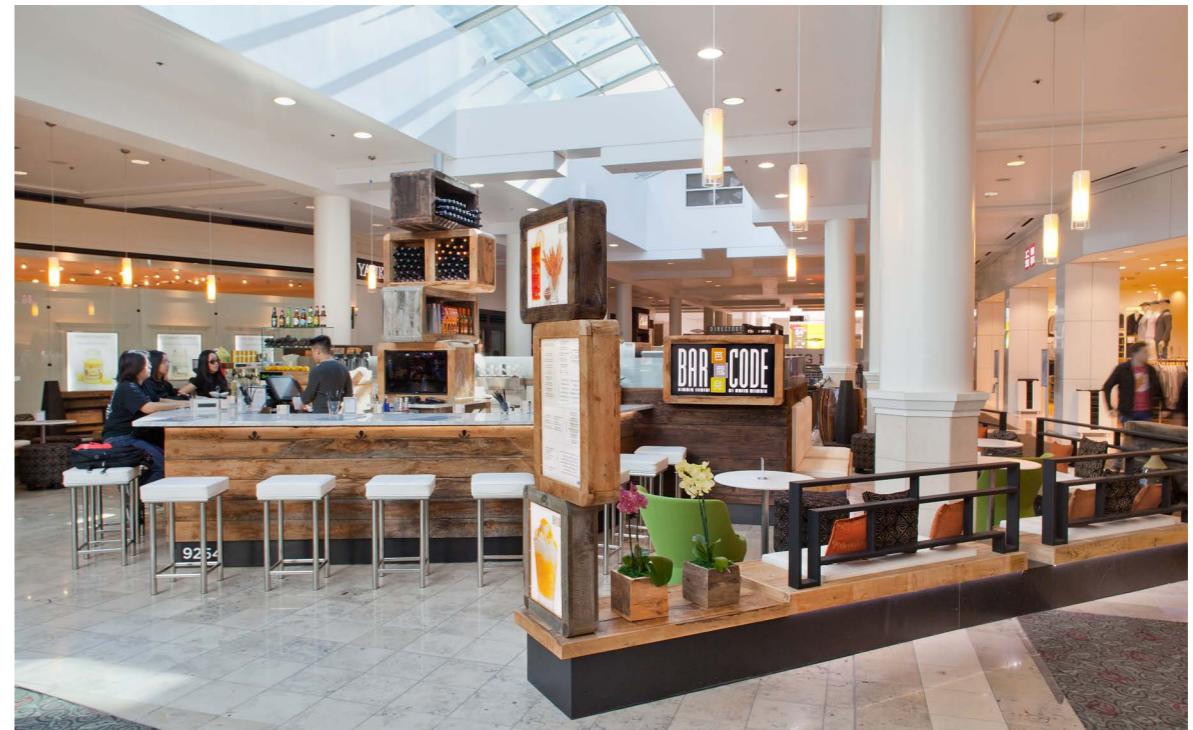

NATURAL, SOPHISTICATED, UNIQUE

> WHIMSICAL

WHIMSICAL



UNEXPECTED, PLAYFUL, COLORFUL

> INVITING

INVITING

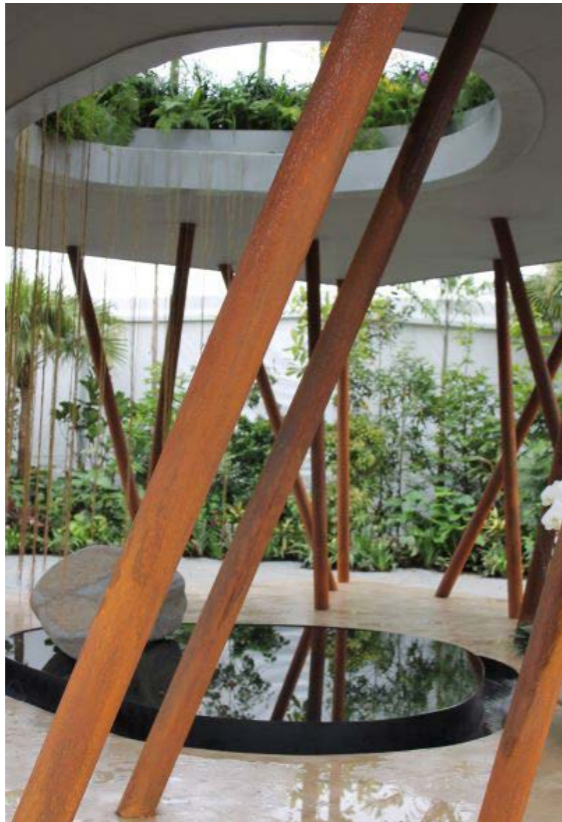

WARM, CALM, OPEN, SOFT

> ARTSY

ARTSY



QUIRKY, AVANT GARDE, SURPRISING

> THEATRICAL

T H E A T R I C A L



DRAMATIC, HIGH CONTRAST, MOVEMENT

DESIGN ELEMENTS AND REQUIREMENTS > CONTENTS

- TRAFFIC FLOW
- QUEUING
- SEATING
- LAYERING ELEVATIONS
- VISUAL MERCHANDISING
- BRANDING
- TECHNOLOGY AND MEDIA
- MATERIALS AND FINISHES
- LIGHTING & ILLUMINATION
- ACCESS GATE
- FLOORING
- STORAGE
- TOE KICK
- PYLONS
- DIMENSIONS

SECTIONS OF INTEREST

The following sections provide additional details and requirements related to this Criteria:

- DESIGN INSPIRATION*
Provides visual inspirations for design aesthetics.
- PROPERTY INFO*
Includes information on the Property's building codes, area permitting, and required contractors.
- SUBMITTALS*
Outlines the requirements on how and what to compile for submittals to the Landlord for design reviews.

WELCOME!

This section provides an overview of the numerous design elements and requirements to consider and follow when designing your kiosk. The elements detailed in this section apply to both dry retail kiosks and "wet" food kiosks that prepare food within the kiosk. The next section will detail specific additional elements for food kiosks.



> TRAFFIC FLOW

TRAFFIC FLOW

Taking into account the flow of mall traffic, an open layout can:

- Increase SKUs. The unit can be shopped from the inside and outside.
- Encourages interactive shopping.
- Let's the customer assess your product before they engage, decreasing your sales transition time.
- Creates a more sculptural design, drawing more attention to your product.

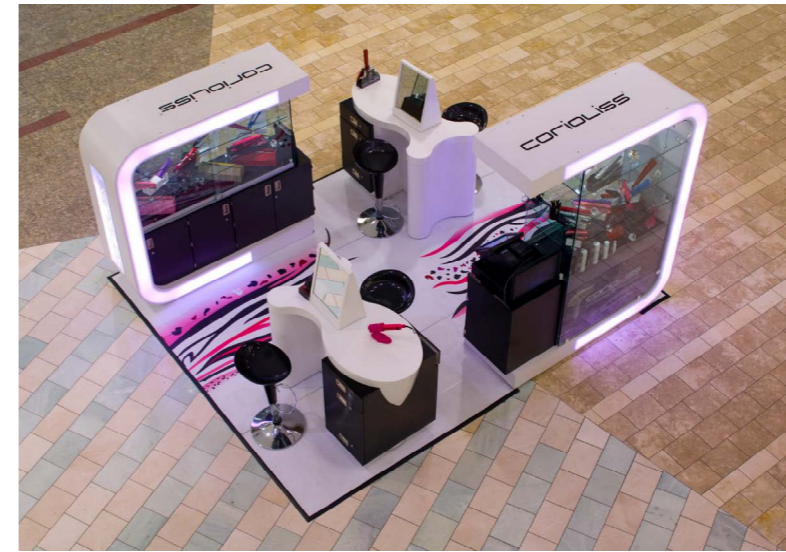
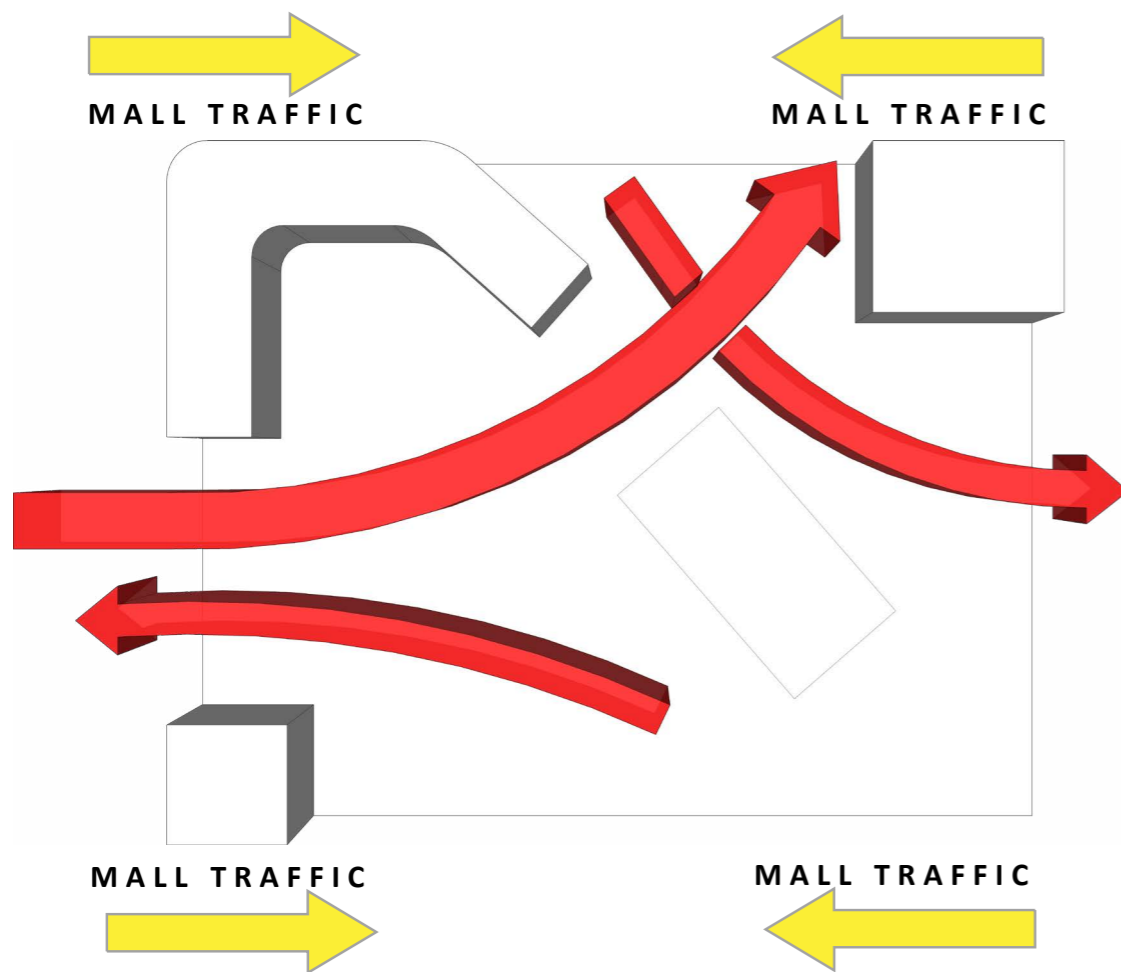

> QUEUING

QUEUING

It is important to consider the flow of Customer traffic as they queue to place an order. Be certain to make accommodations for lines of Customers navigating the space around your kiosk.



> SEATING

SEATING

Macerich's vision is to create food uses as "dwell" areas or destinations for the core Malls.

We encourage curves and angles to differentiate public spaces versus back of house areas for the following reasons:

- Encourages areas for seating and dwelling.
- Creates transitional areas for shopping versus resting.
- Makes for a sculptural design, which in turn draws attention to your business.
- Curves, plants, soft lines create an inviting and relaxing atmosphere to encourage dwell time.

Dedicated kiosk seating is also encouraged.

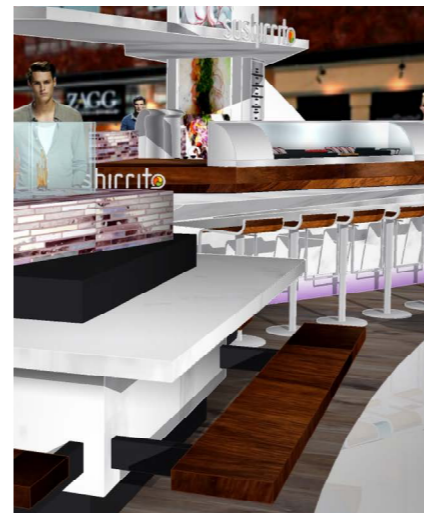
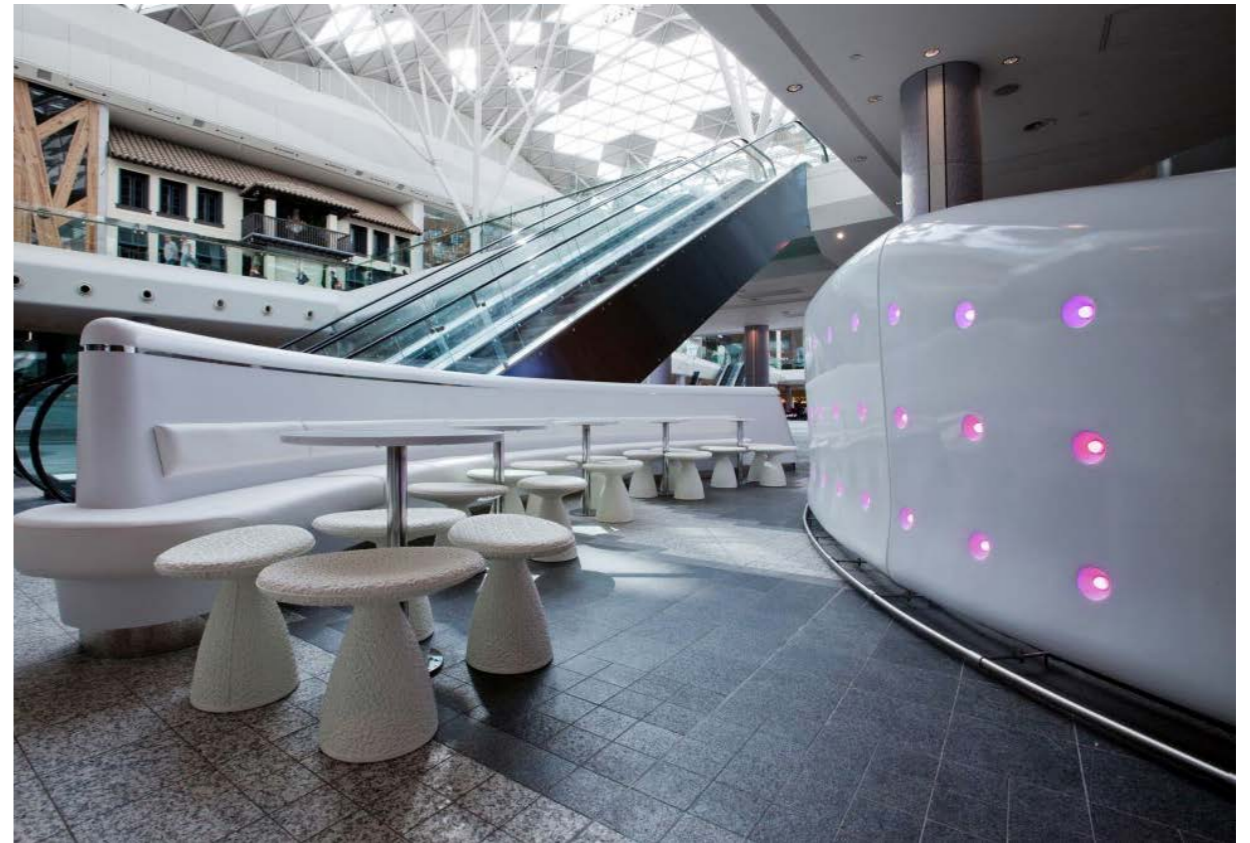

> LAYERING ELEVATIONS

LAYERING ELEVATIONS

Walls and elevations can be used to make a canvas that communicates to your Customer.

An eye catching layered elevation may include:

- Walls with patterns and textures
- Overlays of materials
- Dimensionality
- Molded shapes
- Overlaps to create shadows and depth
- Cove lighting for extra dimensions

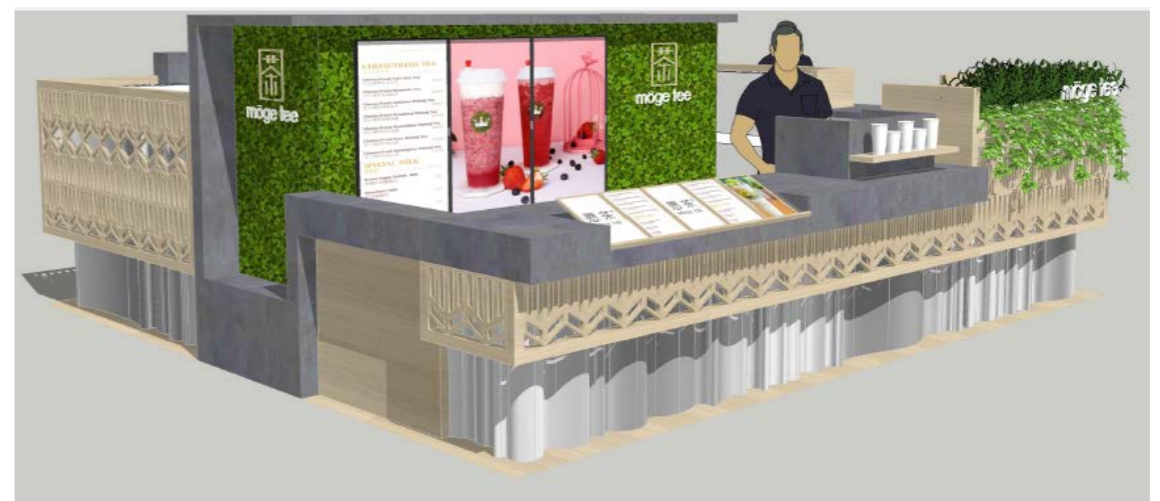

> VISUAL MERCHANDISING

VISUAL MERCHANDISING

Strong visual presentation and merchandising are essential and integral components of retail design.

- Always try to create a triangular composition within style groups or color groups. (display in groups of three or five).
- Start with a center feature, (best sellers / hot items), and merchandise out symmetrically.
- Balance merchandise.
- Color block merchandise to create organized zones.

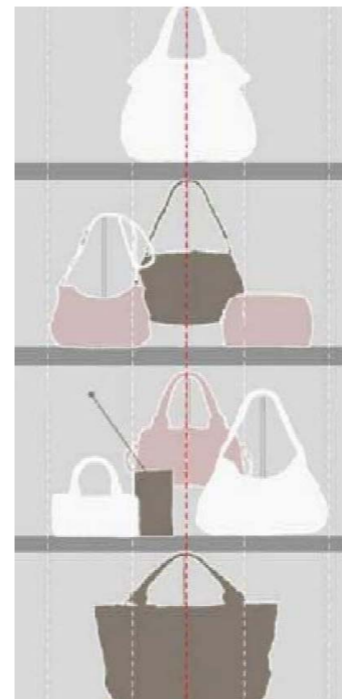
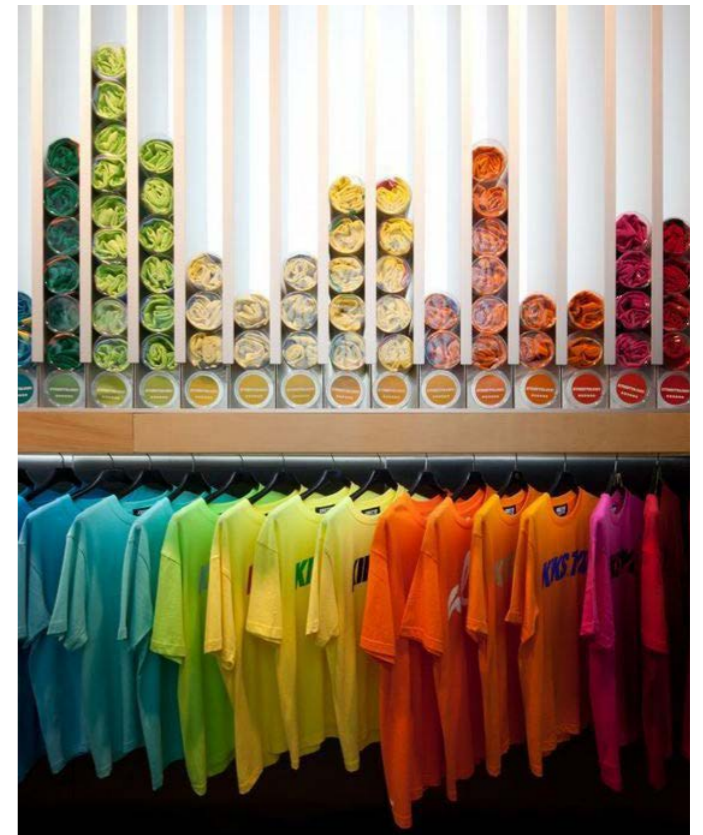

S E T Y O U R S T A G E ,
S E L L A S T O R Y

> BRANDING

BRANDING

A brand is a name, term, design, symbol, color or some other feature that identifies a seller's product or services as distinct from those of other seller's.

Whether you have an established brand or are starting your first business, the kiosk team will work closely with you to enhance your brand look, so you stand out to potential customers and fit with the Macerich experience. This will help you towards the success of your business.

Your branding can be communicated with signage, graphics, materials, shapes, colors, textures, patterns and the overall look and feel of your kiosk, to tell a story and create a lasting experience.

- Taglines are not permitted.
- Graphics must be mounted behind glass or acrylic and secured with stand offs.
- Handwritten signs are not permitted.
- All signage must be approved by the Landlord.



	£2.99	£3.50	£4.50	£2.45	
1 serving	£3.70	£4.25	£5.25	£2.45	30%
2 servings	£4.45	£5.00	£6.00	£2.45	30%
3 servings	£5.10	£5.65	£6.65	£2.45	30%



> TECHNOLOGY & MEDIA

TECHNOLOGY AND MEDIA

Technology can enhance your online operation by transforming your kiosk space into a multifunctional one, that lends itself to being an in-store pick up location, payment booth or advertising billboard.

Integrating technology into your kiosk can:

- Become an extension of you.
- Supplement your sales force with interactive screens for ordering, self-design functions, and more.
- Keep your business connected with your Customer.
- Help you tell a story.
- Help make menu boards easier to update and better communicate your offerings to your Customer via LCD screen loops.

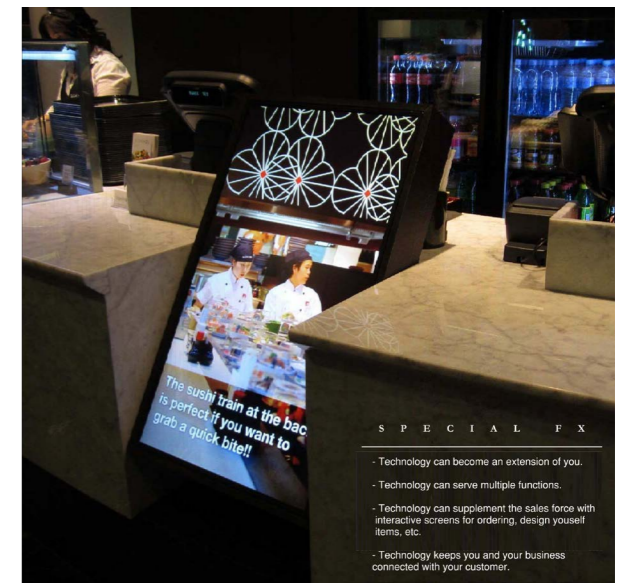

> MATERIALS & FINISHES

MATERIALS AND FINISHES

Kiosks experience heavy foot traffic and engagement. As such, kiosk materials and finishes must be durable and designed to withstand heavy wear and cleaning machinery.

- A material sample board must be submitted for Landlord approval before fabrication can begin.
- Building materials must be fire retardant, fire treated or non-flammable. Class A materials per building codes must be used.
- Selected materials must be authentic and natural such as woods, stones, reclaimed woods, mosaic tiles, etc.
- Plastic laminates are not permitted with the exception of color core or wood pattern high performance plastic laminates.



Stone and solid surfaces

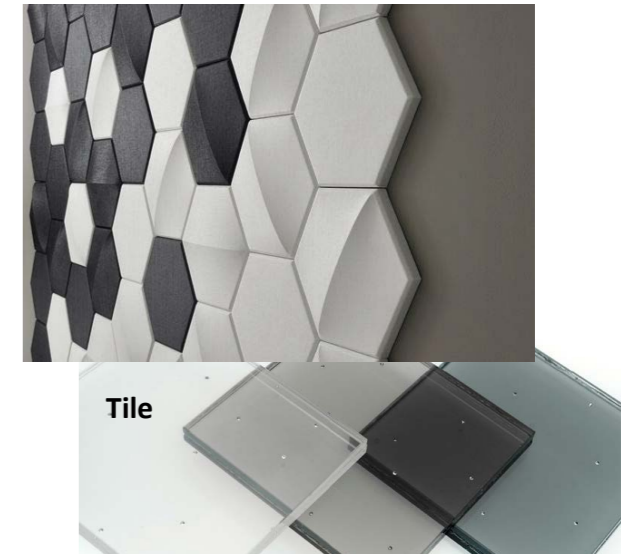

Tile



Wood



Concrete

> LIGHTING & ILLUMINATION

LIGHTING AND ILLUMINATIONS

Lighting can be used to draw attention, create depth, and enhance the overall design of your kiosk.

- Light fixtures must be low profile and approved by the Landlord.
- Case lighting must be seamlessly integrated into the design.
- Ensure that the light source is concealed.
- If your kiosk is located under the ceiling, additional lighting elements may be considered but it must be connected to the Tenant's circuit.
- No track lighting or cable hung fixtures are allowed.
- No overhead canopies are allowed.
- All lighting must meet applicable building codes and safety requirements and will require Landlord approval prior to installation.



> FLOORING

FLOORING

Flooring is an important design element in an open kiosk layout for the following reasons:

- It is inviting and welcoming.
- It defines your footprint.
- Conduits can be run between cabinetry beneath the floor.

We encourage a wood flooring material like plank, for a warm look and feel.

Flooring requirements include:

- All flooring must be approved by Landlord prior to installation.
- It is a code requirement to comply with the ADA. (1" = 12" - transitional slope).
- Flooring must be laid over existing mall flooring. Mall flooring is not permitted to be removed.

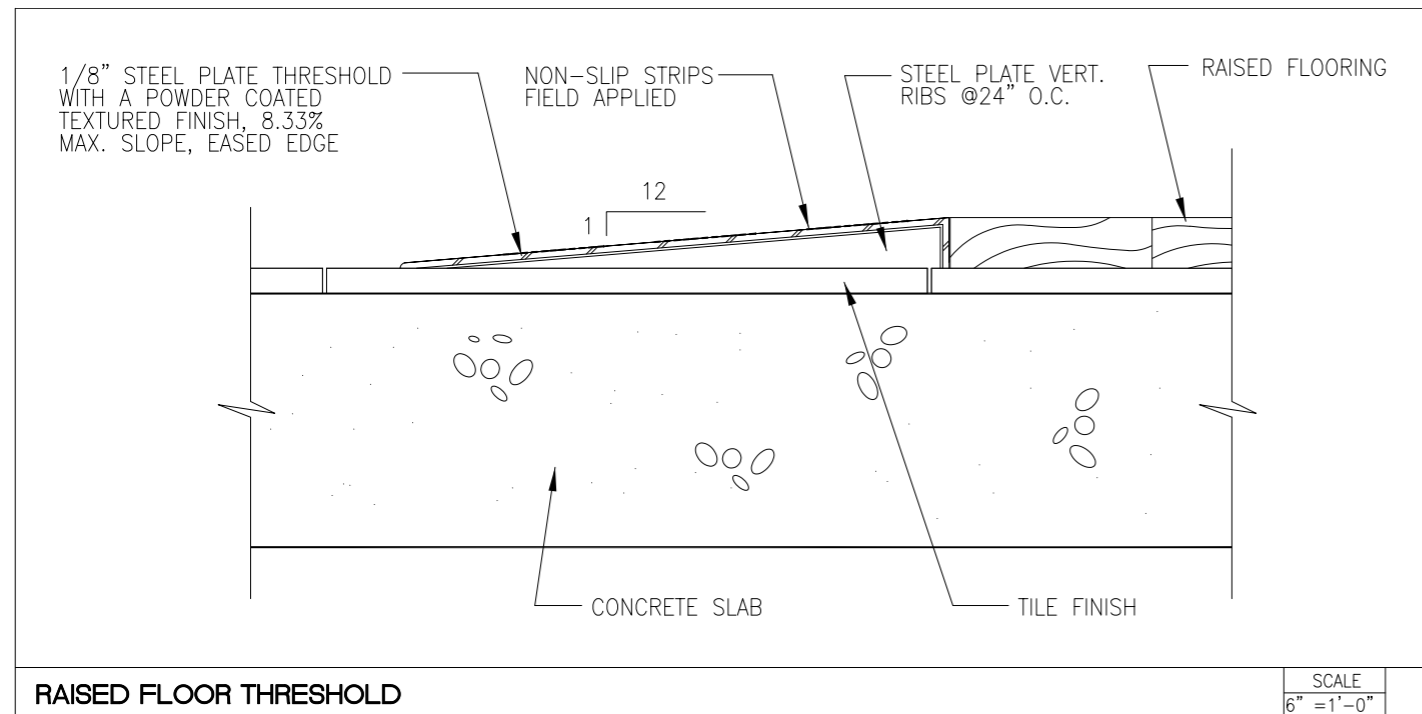

> ACCESS GATE

ACCESS GATE

A gate to enter a kiosk is a necessity. However it is not necessary for the customer to know where the gate is located.

- The gate must be seamlessly integrated into the overall design, to avoid being an eyesore.
- The gate shall be installed no more than 1" maximum above the finished floor.



> STORAGE

STORAGE

Maximizing sales volume naturally requires product storage within your kiosk. Storage should be integrated into your design to make it invisible to the customer.

- All interior storage must have doors or fixed fronts within the retail space.
- All cabinet hardware must be low profile, commercial grade stainless steel.
- Integrate all countertop displays into the design. No freestanding loose spinners or displays are permitted.
- All front counter service equipment must be shrouded to conceal cables or loose items from public view.
- Bins and brochure holders must be integrated into the overall design.
- Low profile hardware for cabinets and drawers are required.
- Merchandise must be placed in shelving that is designed in line with the kiosk's overall look and feel.
- Equipment, cords, cables, and loose items are required to be hidden from the public view. Your kiosk design should include shrouding.

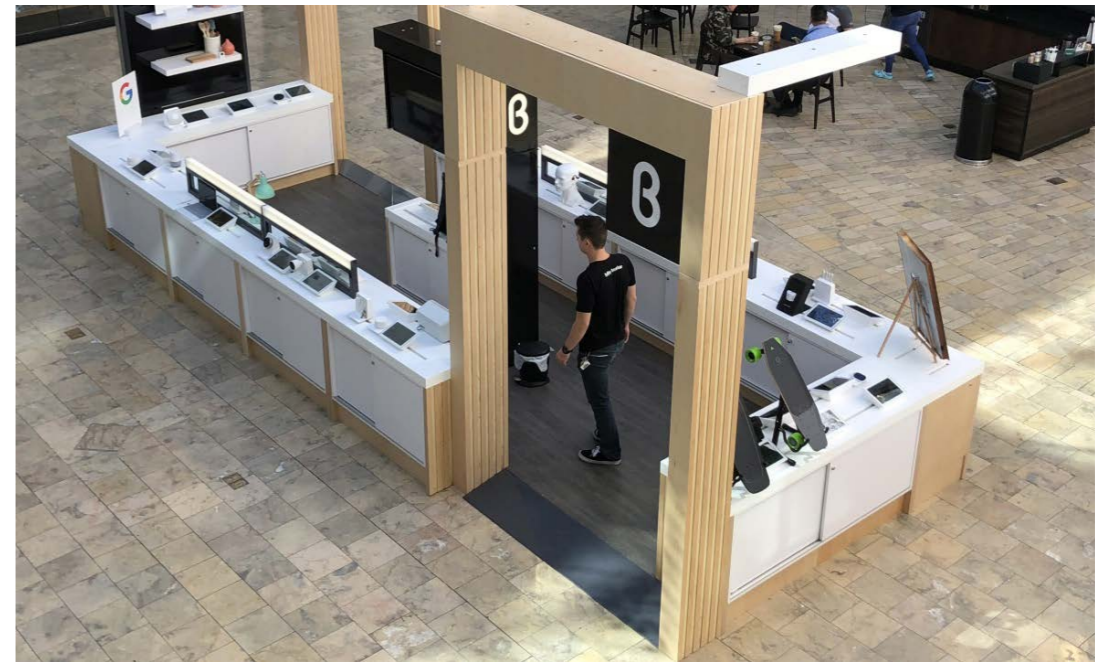

> TOE KICK

TOE KICK

Toe kicks are important as they minimize damage to your kiosk from foot traffic and cleaning machinery.

- Kick material must be durable.
- Kick should be 6" high and 3" inset.
- An 1/8" metal extrusion at the toe kick is required to protect kiosk finishes from foot traffic and cleaning machines.



> PYLONS

PYLONS

We encourage your design incorporate a pylon shape that enhances your brand experience and communicates what you are offering.

If your lease line includes a column, you have a unique opportunity to brand it with additional signage and accent lighting.

- Design must be integrated and coherent with the retail design.
- Max allowable size is 7' tall by 3' wide.
- Secondary pylons are encouraged at a maximum size of 4' tall by 3' wide.
- Freestanding neon or neon lit signs are not permitted.
- All signage must be approved by the Landlord prior to installation.

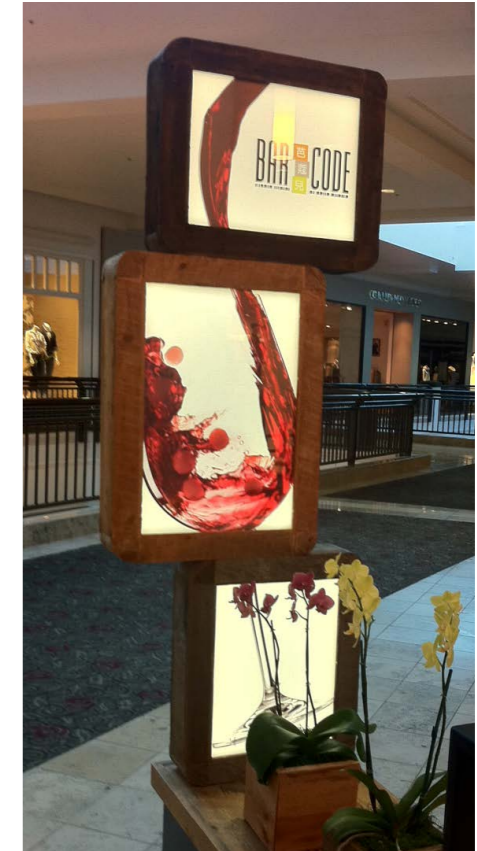

> DIMENSIONS

DIMENSIONS

We want your kiosk to stand out and attract customers through excellent design. With that in mind, it is also important to keep common area sight lines open. To achieve this, we have a few dimensional requirements to follow:

- A maximum height for opaque walls is 4'-0", with a 1'-0" translucent glass shroud up to a 5'-0" total height, where required by the Health Department.
- Max allowable pylon size is 7'-0" tall by 3'-0" wide.
- Secondary pylons are encouraged at a maximum size of 4'-0" tall by 3'-0" wide.

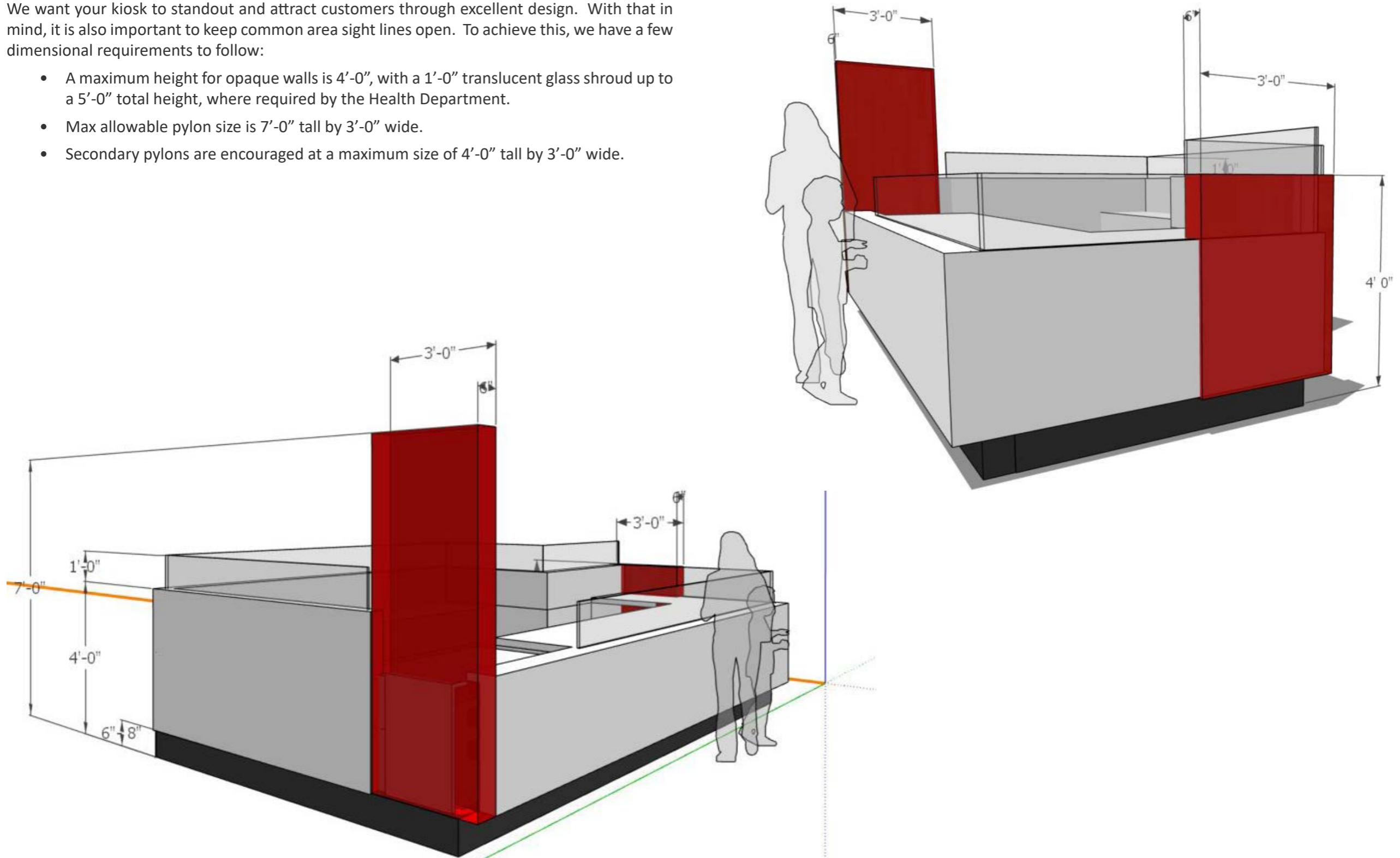

FOOD DESIGN ELEMENTS AND REQUIREMENTS > CONTENTS

- FOOD DISPLAY**
- FOOD PREPARATION AREA**
- MENU BOARDS**
- CONDIMENTS AND UTENSILS**

SECTIONS OF INTEREST

The following sections provide additional details and requirements related to this Criteria:

- DESIGN INSPIRATION**
Provides visual inspirations for design aesthetics.
- PROPERTY INFO**
Includes information on the Property's building codes, area permitting, and required contractors.
- SUBMITTALS**
Outlines the requirements on how and what to compile for submittals to the Landlord for design reviews.

A FEAST FOR YOUR EYES!

This section provides an overview of the specific design elements and requirements to consider for a “wet” food producing kiosk. It is important to embrace the cooking and display of food as an integral design element to your kiosk. Food is a great tool to entice the consumer.



> FOOD DISPLAY

FOOD DISPLAY PRESENTATION

We encourage you to incorporate food display of your goods to showcase your brand to Customers. Presenting freshly made options from the menu will entice the eyes of your customer and provide an instant way to purchase an item. Labeling your items helps identify your offerings.

- Food displays must be appetizing and behind clean and clear glass.
- Labels should accent the design of your kiosk.
- Signage should be professionally printed on card stock and utilize proper display methods.



DISPLAY THE GOODS IN AN APPETIZING MANNER.



> FOOD PREPARATION AREA

FOOD PREPARATION AREA

Visual food preparation is an added value to your brand experience, resulting in excitement and interaction for the Customer.

- Obstructive overhead canopies are not permitted. An alternative solution to an overhead canopy should be used if one is required by the Health Department.
- Check local building codes for requirements on plumbing venting inside a wall or if it occurs on the exterior wall.
- Odor producing equipment is not permitted. Tenants must enclose all odor within their premise.

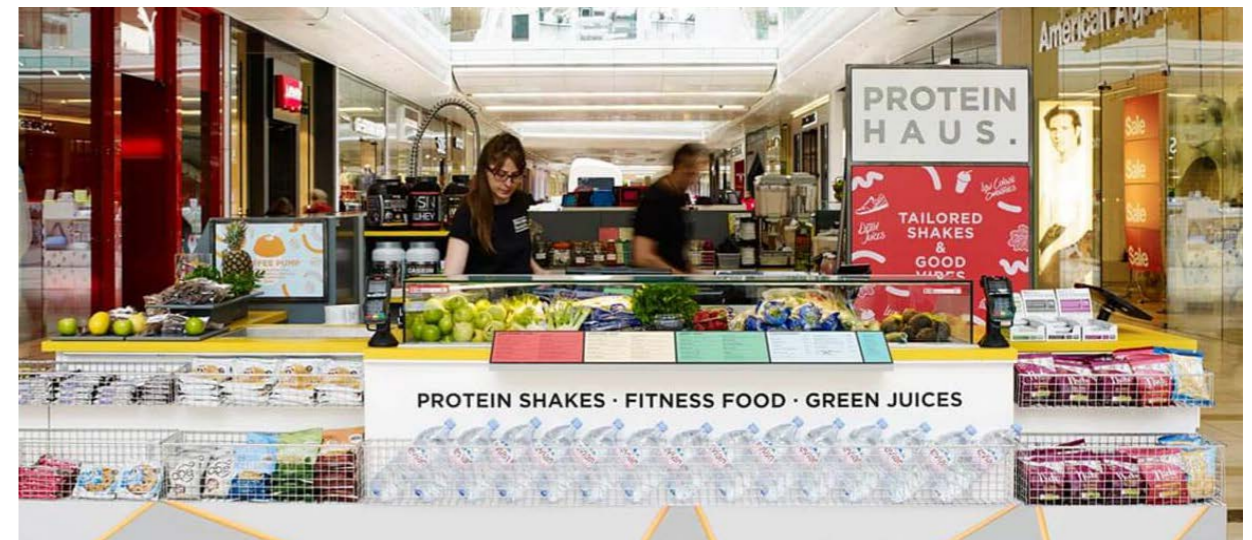

> MENU BOARD

MENU BOARD

Your menu board is a vital brand element to communicate your product to the Customer.

- Design must be integrated and coherent with the retail design.
- Loose menu boards are not permitted.
- The top of the menu board may not exceed a height of 5'. The only exception is when the menu board is located on a pylon.

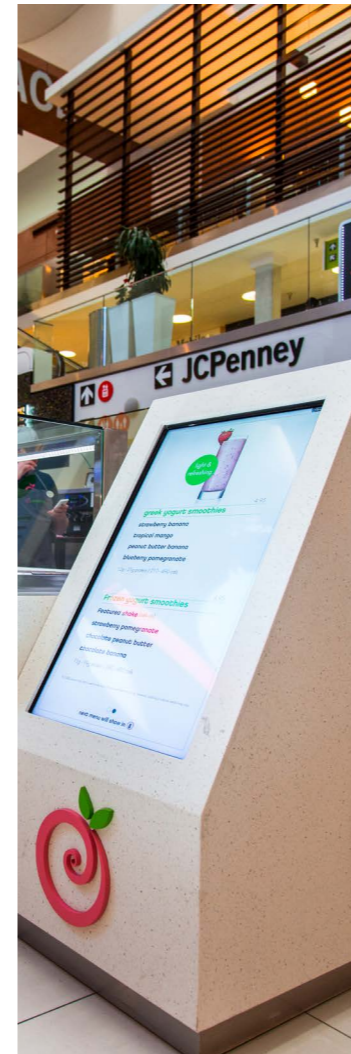

> CONDIMENTS & UTENSILS

CONDIMENTS AND UTENSILS

Condiments, utensils, napkin holders, etc., can be an eyesore if not properly accounted for in the kiosk design.

- Items must be integrated seamlessly into the overall kiosk design.
- Loose items on the countertops are not permitted.



> ELECTRIC / DATA / PLUMBING / STORAGE

OVERVIEW

The Technical Criteria is designed to provide building details and design requirements for the Property's technical systems.

It is the Tenant's responsibility to verify existing conditions and comply with all applicable codes and standards for all technical systems.

Tenants are required to adhere to the full Criteria during their design and construction.

ELECTRIC

Most retail kiosk spaces are typically provided low voltage power stubbed into a J-Box under the floor. In certain kiosk locations, more power exists. It is the responsibility of the Tenant to field verify the amount of existing power in their Premises, to ensure it suits the Tenant's needs, prior to signing the Lease.

Tenant kiosk installations are typically required to tap into the provided power, and distribute inside their kiosk. The following requirements must be met:

- **IDENTIFY** all Tenant equipment in the Mall electric room with clear labels that include the Tenant name and space number.
- **CUTTING AND PATCHING** must be provided by Tenant.
- **MATERIAL AND EQUIPMENT** must be new and of a commercial grade with UL Labels and where such labeling applies.
- **WATERTIGHT FLOOR BOXES** are required.
- **EXPOSED WIRING** is not permitted. All wiring of any type must be installed in conduit or must be metal clad cable (MC). Metal clad cable will only be allowed for concealed branch circuit wiring within the demised premises. Flexible conduits must be used for connections to vibrating equipment.
- **EXPOSED LOW VOLTAGE** wiring must be plenum graded.

DATA AND COMMUNICATIONS

Kiosk spaces are typically provided an empty conduit with a pull string stubbed into a J-Box under the floor.

- **DATA SETUP AND SERVICE INSTALLATION** is the Tenant's responsibility to coordinate direct through Granite Grid. Other data providers are not permitted at this property as they do not have an access agreement in place.
- **TELEPHONE DEMARC WORK** must be performed by Landlord's approved telephone subcontractor, Granite Grid.
- **TELEPHONE SERVICE** is the Tenant responsibility to coordinate directly through Granite Grid and install within their premises.

PLUMBING

Kiosk spaces may or may not have existing wet utilities. It is the responsibility of the Tenant to field verify the wet utilities in their Premises, to ensure it suits the Tenant's needs, prior to signing the Lease.

Tenant kiosk installations are typically required to core into the floor, tap into the provided plumbing, and distribute inside their kiosk. The following requirements must be met:

- **GARBAGE DISPOSALS** are not allowed.
- **HAIR RECEPTORS** must be installed on all sinks, basins, and special sanitary units which may in any way receive human or animal hair.
- **GREASE INTERCEPTORS** must be installed within the kiosk footprint.
- **KITCHEN SINKS** including pot sinks, scullery sinks, pre-wash sinks and other kitchen units must be connected to a grease trap as per code.
- **DISHWASHERS** may not be connected to grease trap.
- **OIL COLLECTION AND HAULING SYSTEM** is required for Tenants with fryers or other grease/oil generating equipment that does not run through an interceptor. Landlord does not provide a centralized collection point.
- **FLOOR PENETRATIONS AND PLUMBING** by Tenants must be coordinated with the Landlord.

PROCESS > DESIGN KICKOFF / DESIGN SUBMISSION / PERMITTING & CONSTRUCTION

This section provides a brief overview of the design, permit, and installation process steps to get your kiosk open.

DESIGN KICKOFF

We want to help you create an incredible kiosk to maximize your brand’s potential. Your Tenant Coordinator will contact your team to schedule a design kickoff call. The purpose of this call is to collaborate on your design intent and help you understand the requirements in this Criteria.

DESIGN SUBMISSION AND REVIEW

Requirements on how and what to submit for the Landlord drawing review of your kiosk can be found in the [SUBMITTALS CRITERIA](#).

PERMITTING AND CONSTRUCTION

An overview of both the City/Municipalities permit process and the Landlord’s construction requirements can be found in [PROPERTY INFO](#).

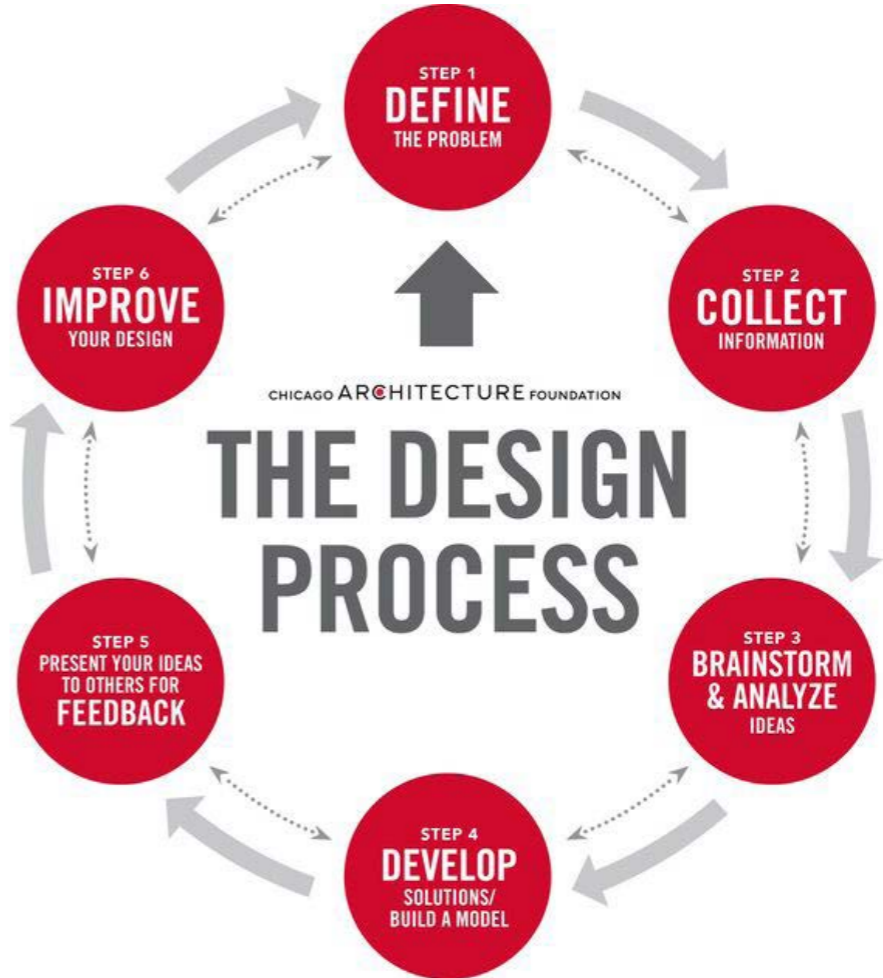

DESIGN DETAILS > GLASS SHROUD / GATE

The following design details are required to be shown in your final design drawings. These details will help to ensure your kiosk is sturdy and built to last.

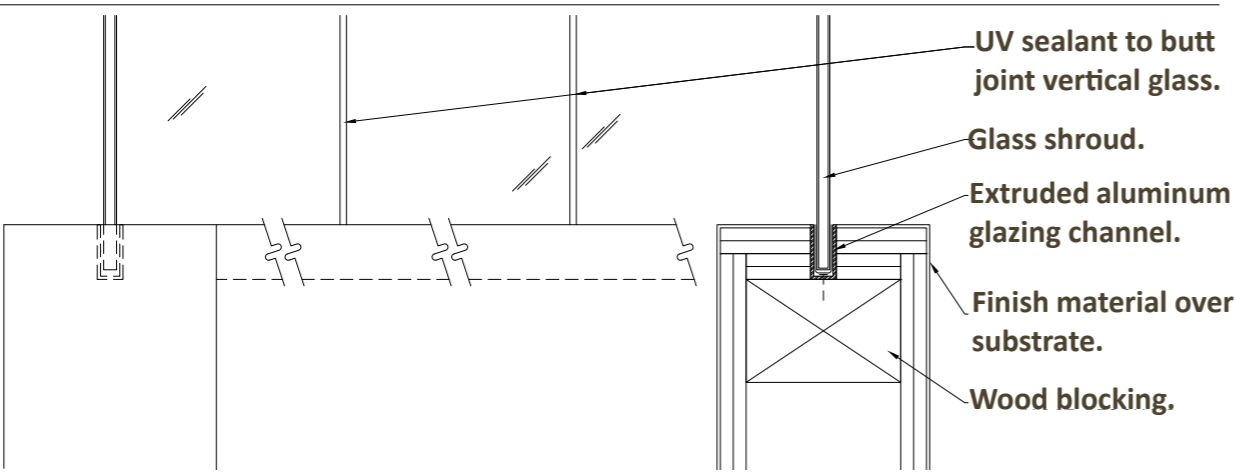

GLASS SHROUD DETAIL

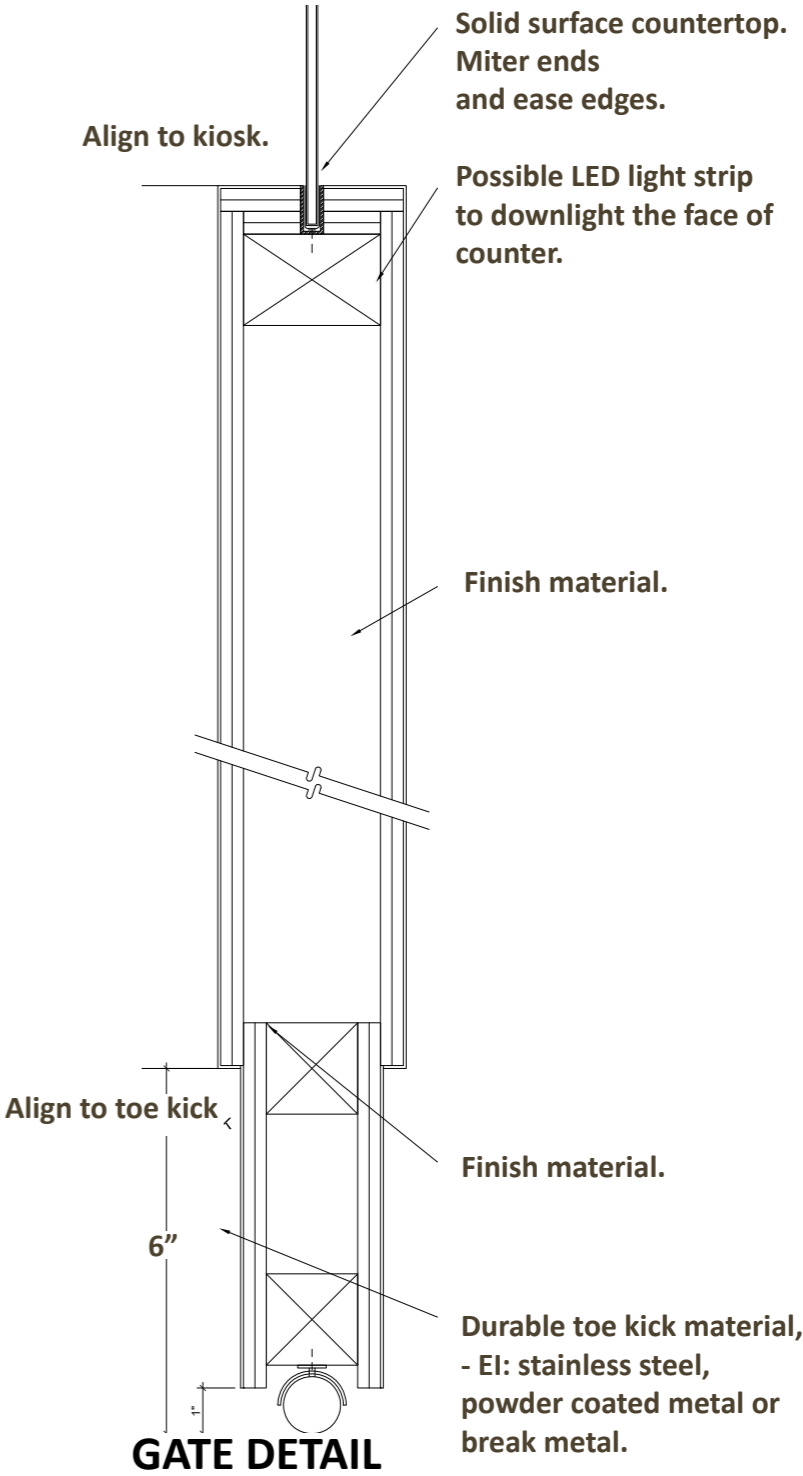

GATE DETAIL

DESIGN DETAILS > CORNER / GRAPHIC FRAME

Note: Can be used for vertical corner only.

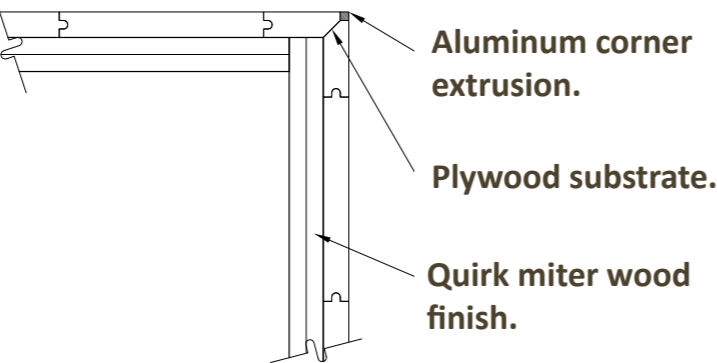

CORNER DETAIL

Note: Can be used for vertical corner only.

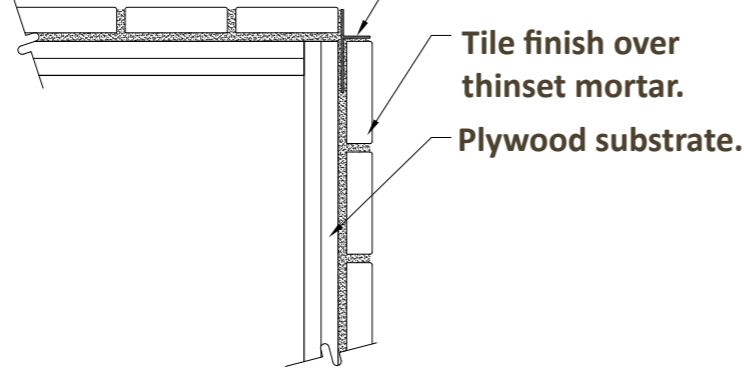

CORNER DETAIL

Note: For interchangeable frameless graphic panels, change graphic from back via concealed hinges and reveal details. (for back lit panels as well to replace lights). Use concealed / magnet activated locks to secure door.

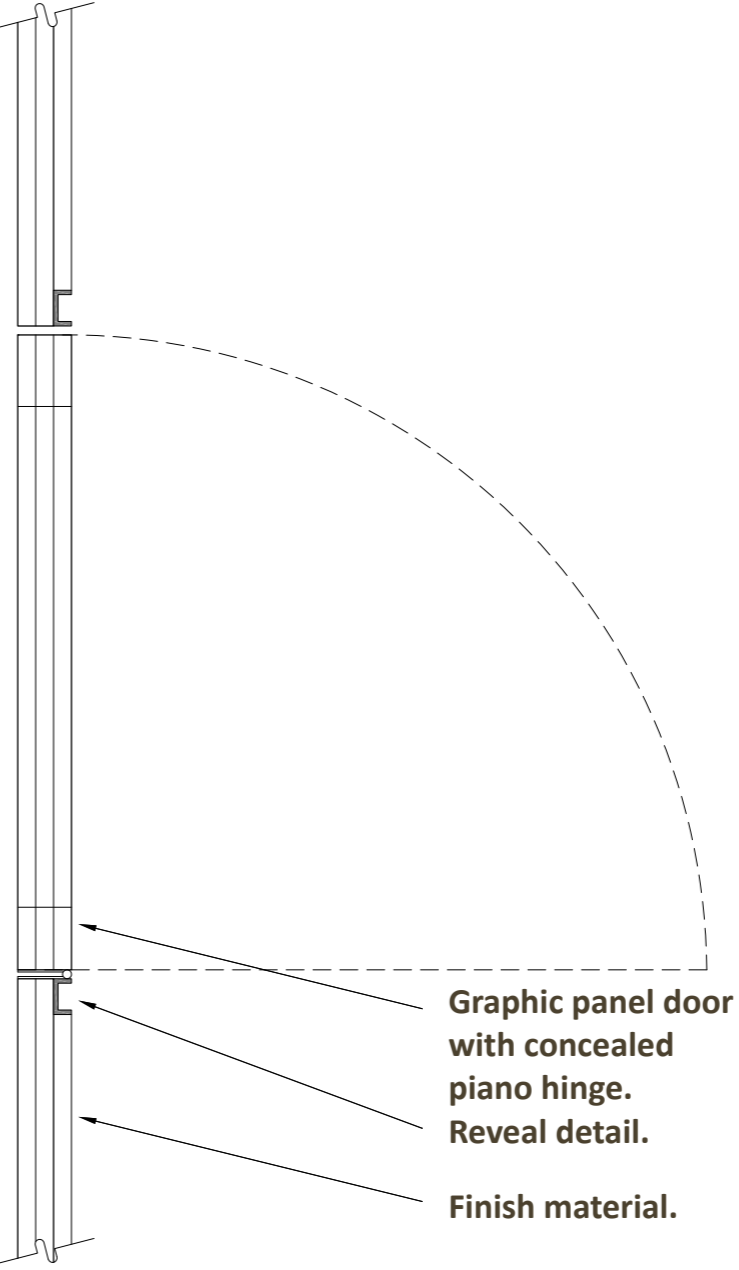

GRAPHIC FRAME DETAIL

BUILDING DETAILS CONTENT OVERVIEW

FIRST LEVEL BUILDING DETAILS

- ZONE PLAN
- STOREFRONT PHOTOS
- NEUTRAL PIER DETAIL
- STOREFRONT DETAIL

SECOND LEVEL BUILDING DETAILS

- ZONE PLAN
- STOREFRONT PHOTOS
- NEUTRAL PIER DETAIL
- STOREFRONT DETAIL

THIRD LEVEL BUILDING DETAILS

- ZONE PLAN

FOURTH LEVEL BUILDING DETAILS

- ZONE PLAN

HVAC

- ZONE PLAN

This section provides a zone map of each of Kings Plaza's four floors as well as architectural details of storefront elements.

Tenant and Tenant's Architect are responsible for surveying and addressing the architectural drawings surrounding their space.



> ZONE PLAN

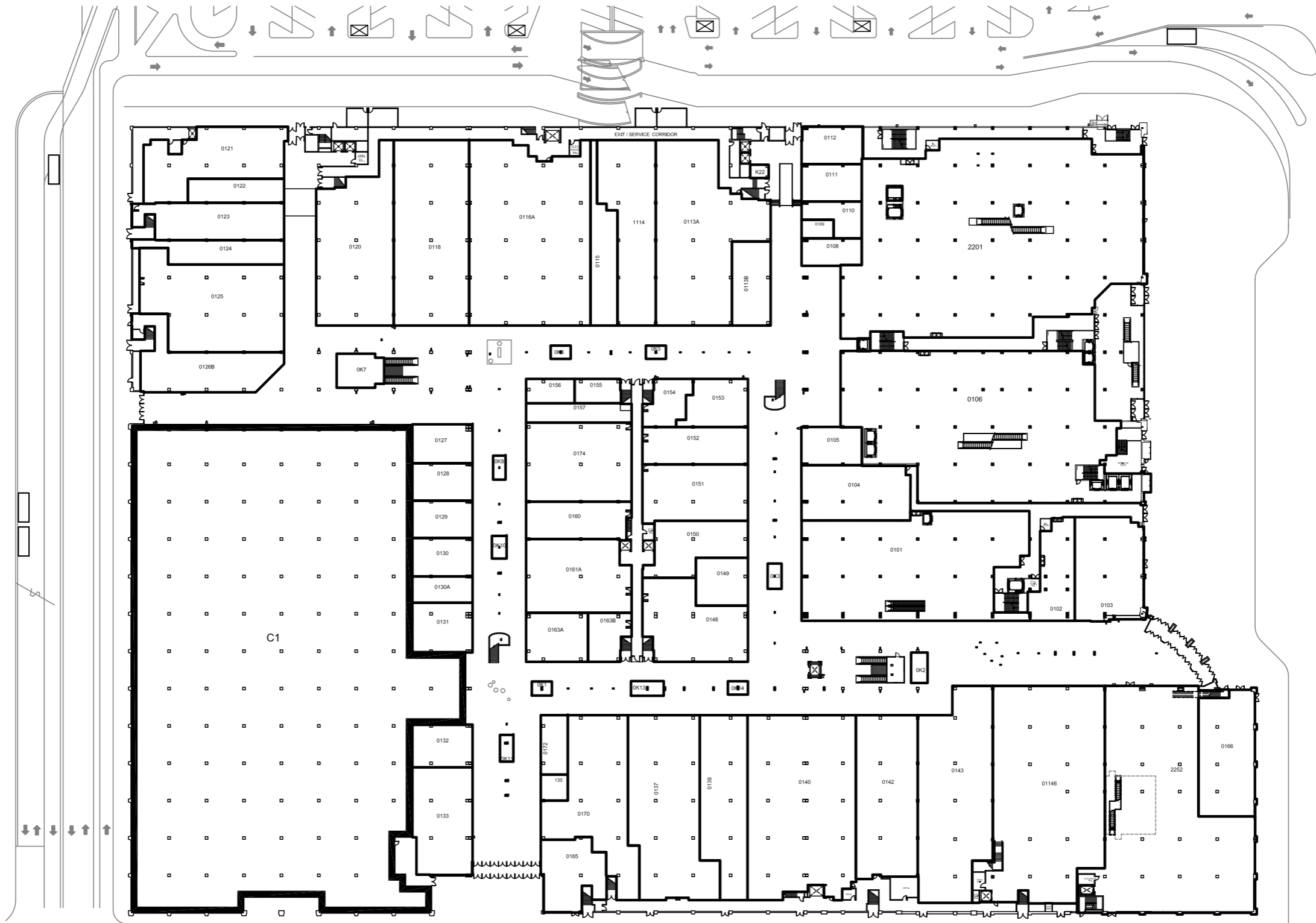

> STOREFRONT PHOTOS



> NEUTRAL PIER DETAIL

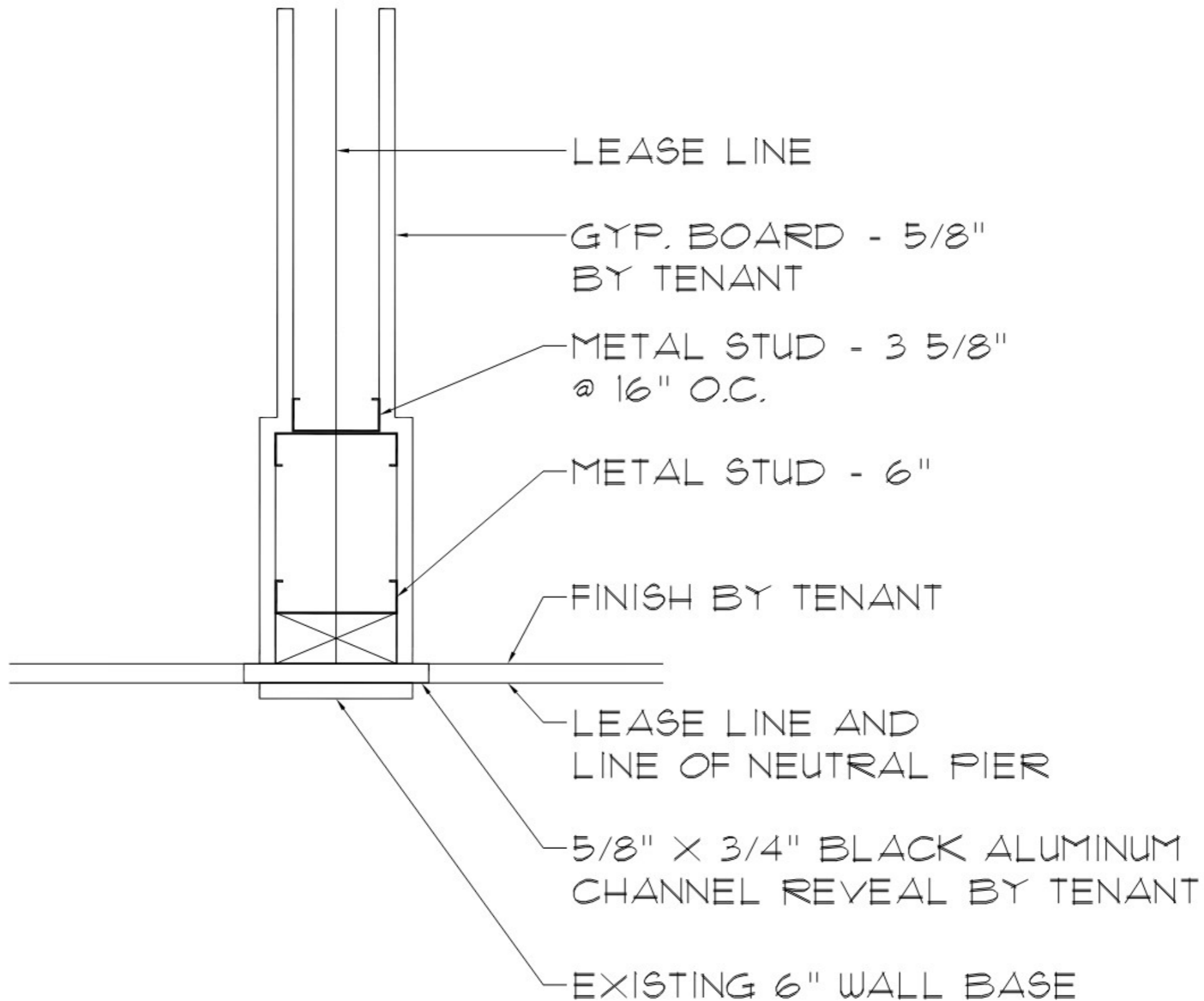

> STOREFRONT DETAIL

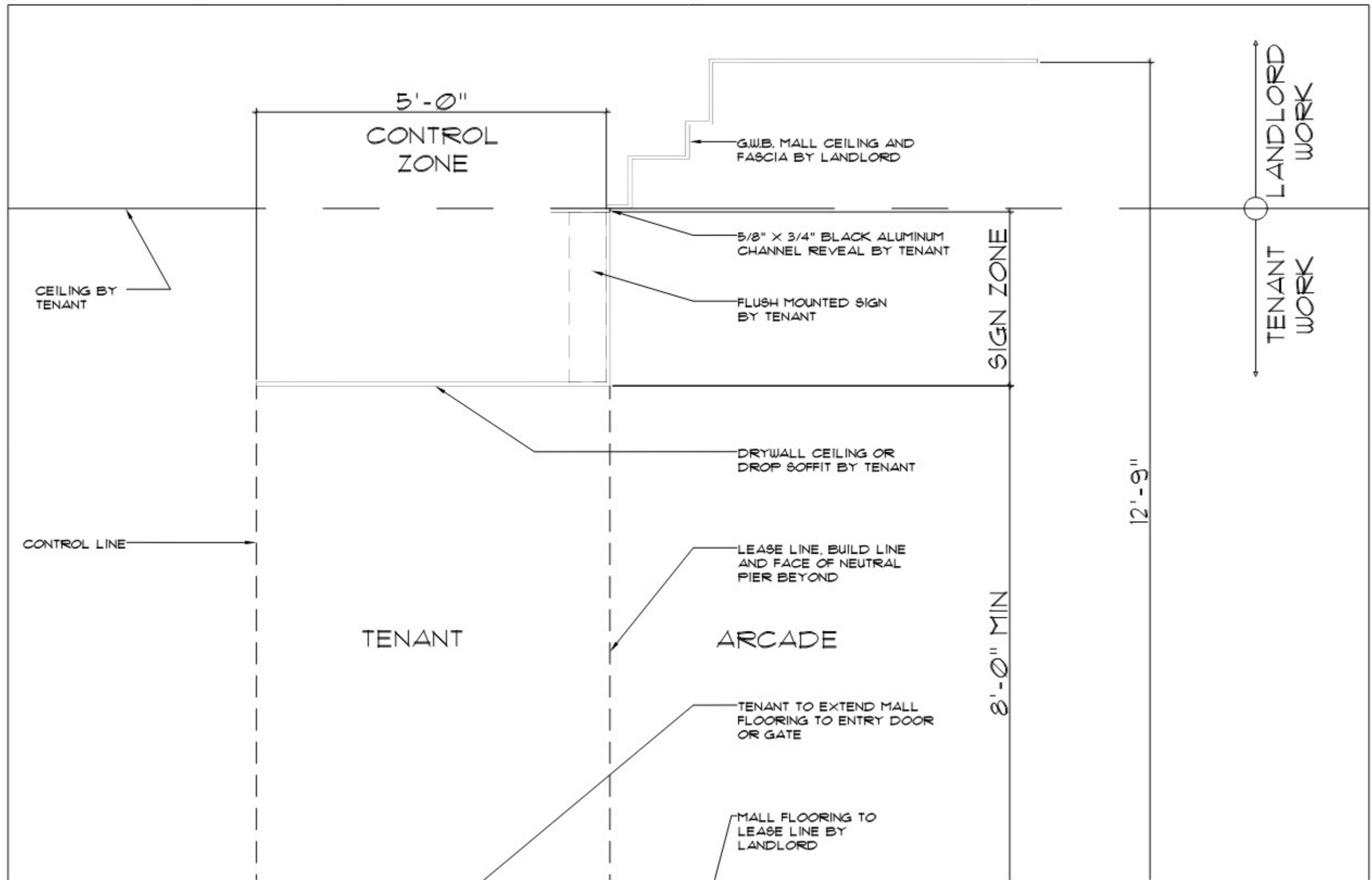

> ZONE PLAN

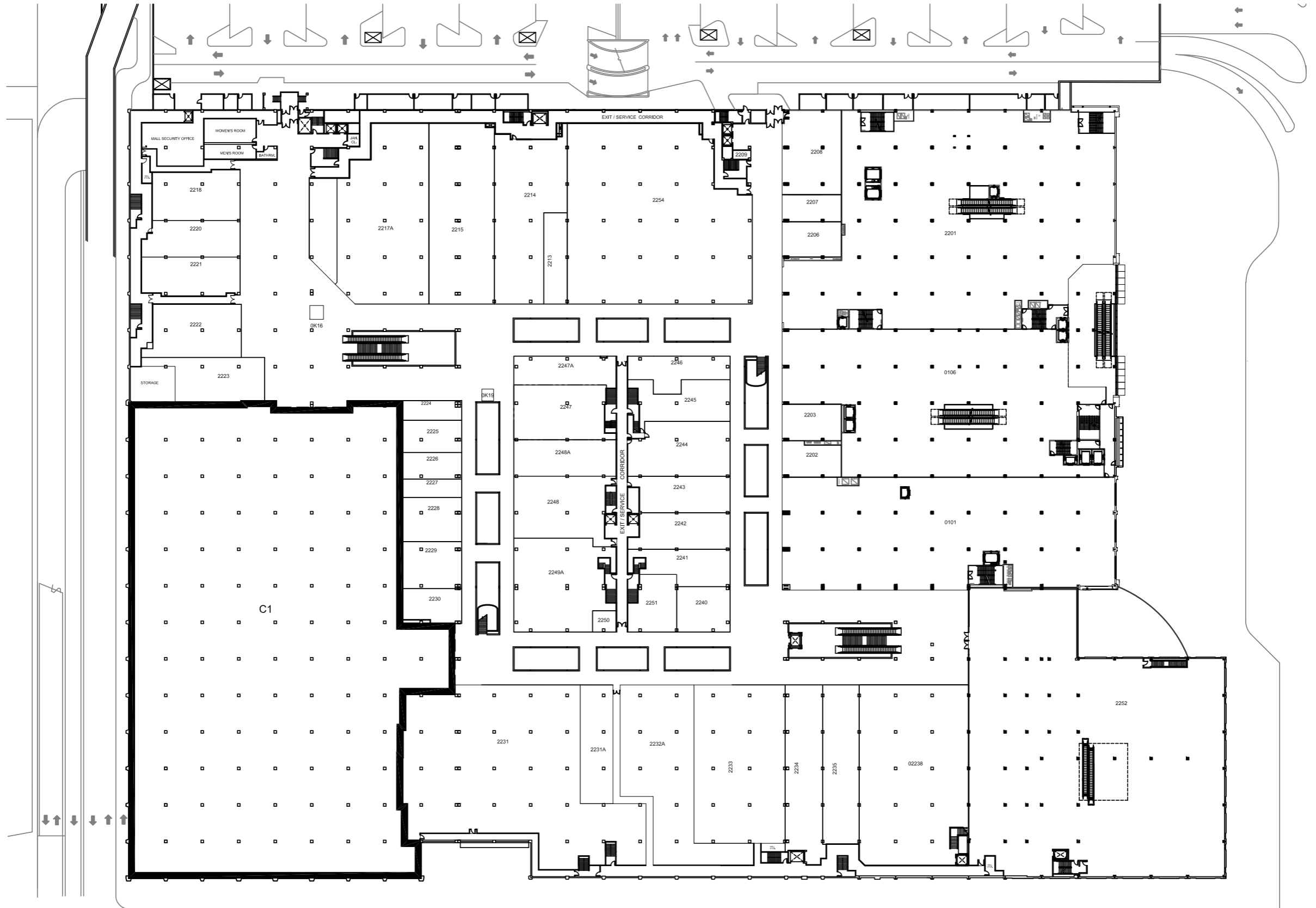

> STOREFRONT PHOTOS



> NEUTRAL PIER DETAIL

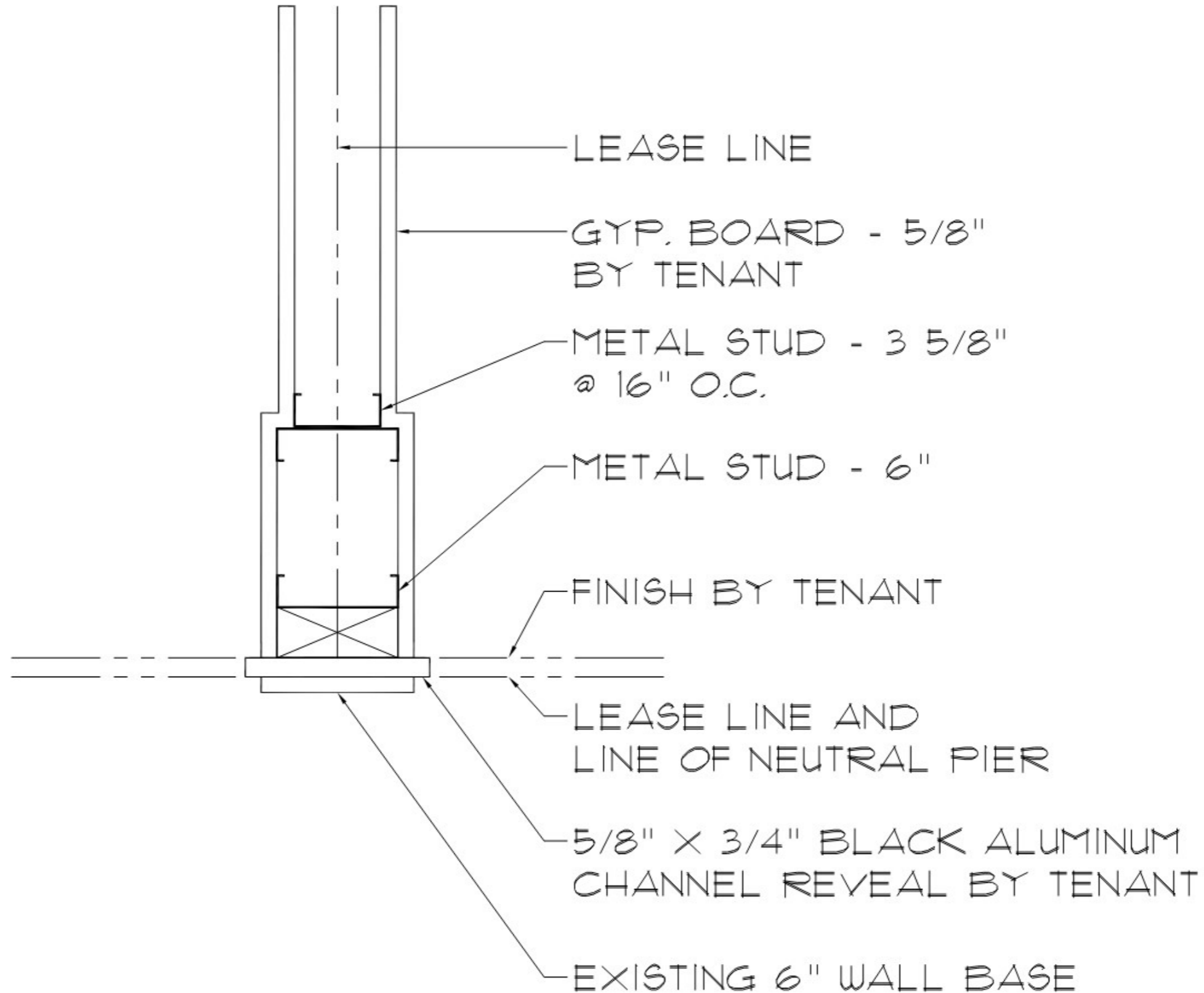

> STOREFRONT DETAIL

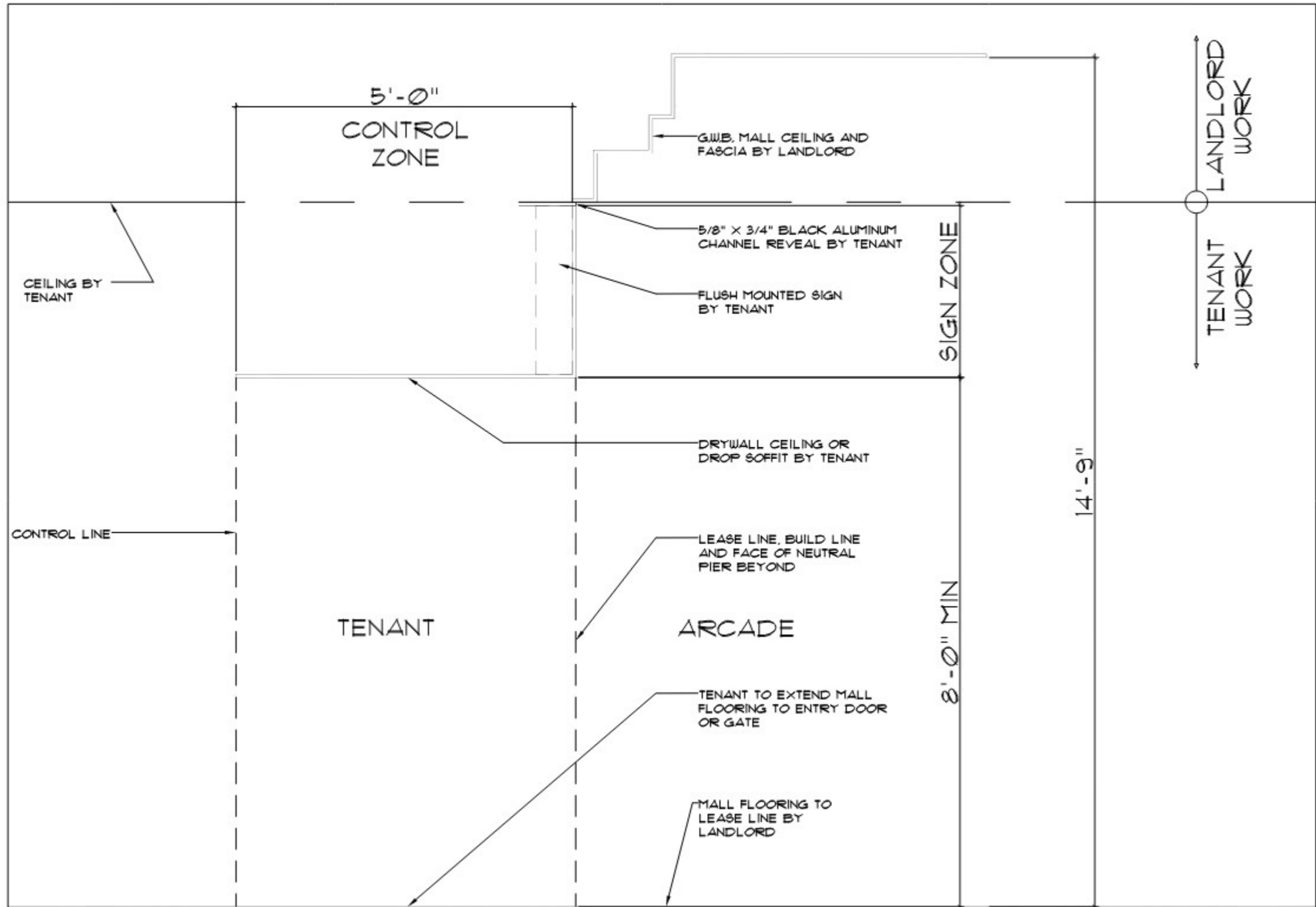

> ZONE PLAN

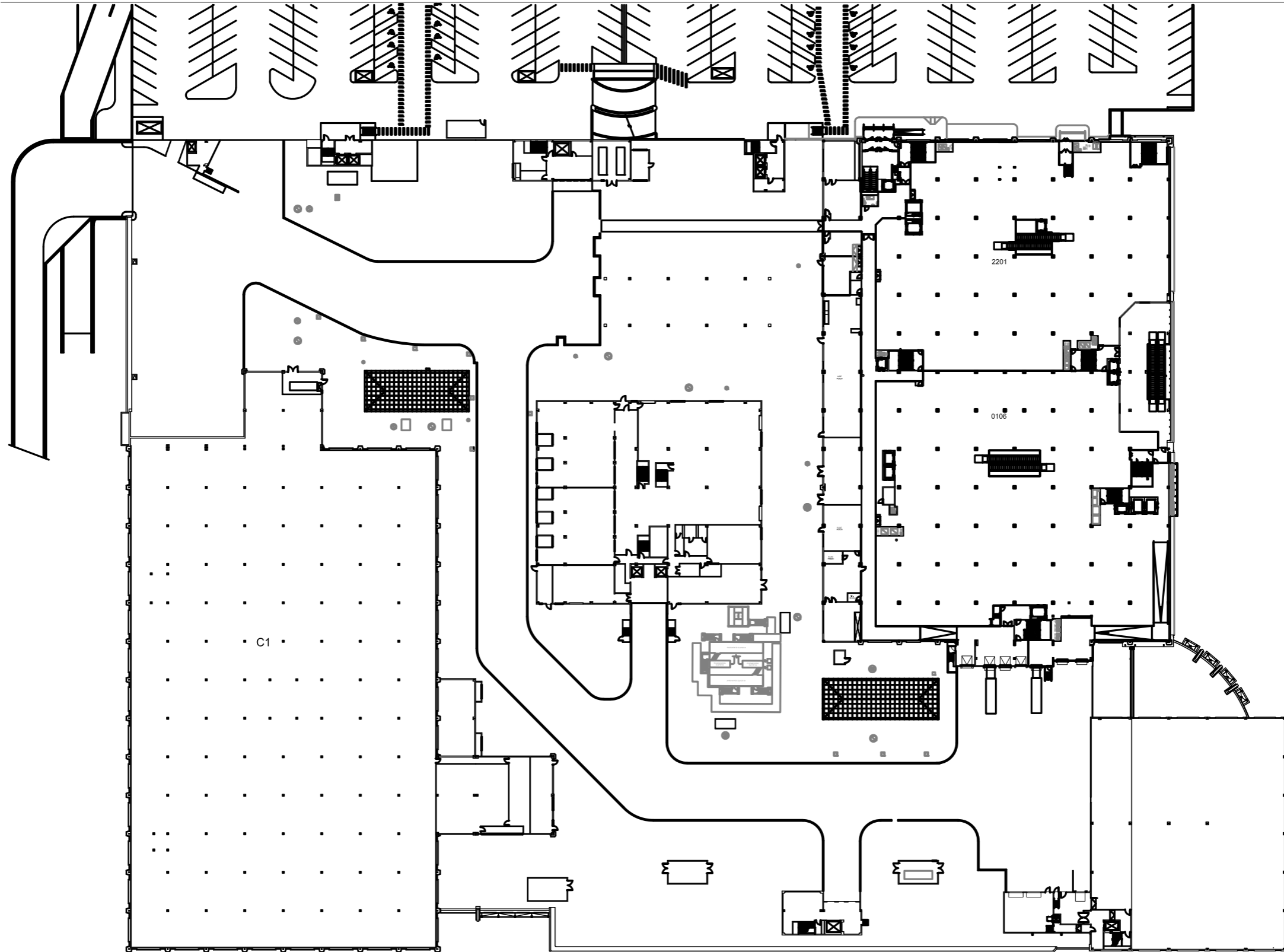

> ZONE PLAN

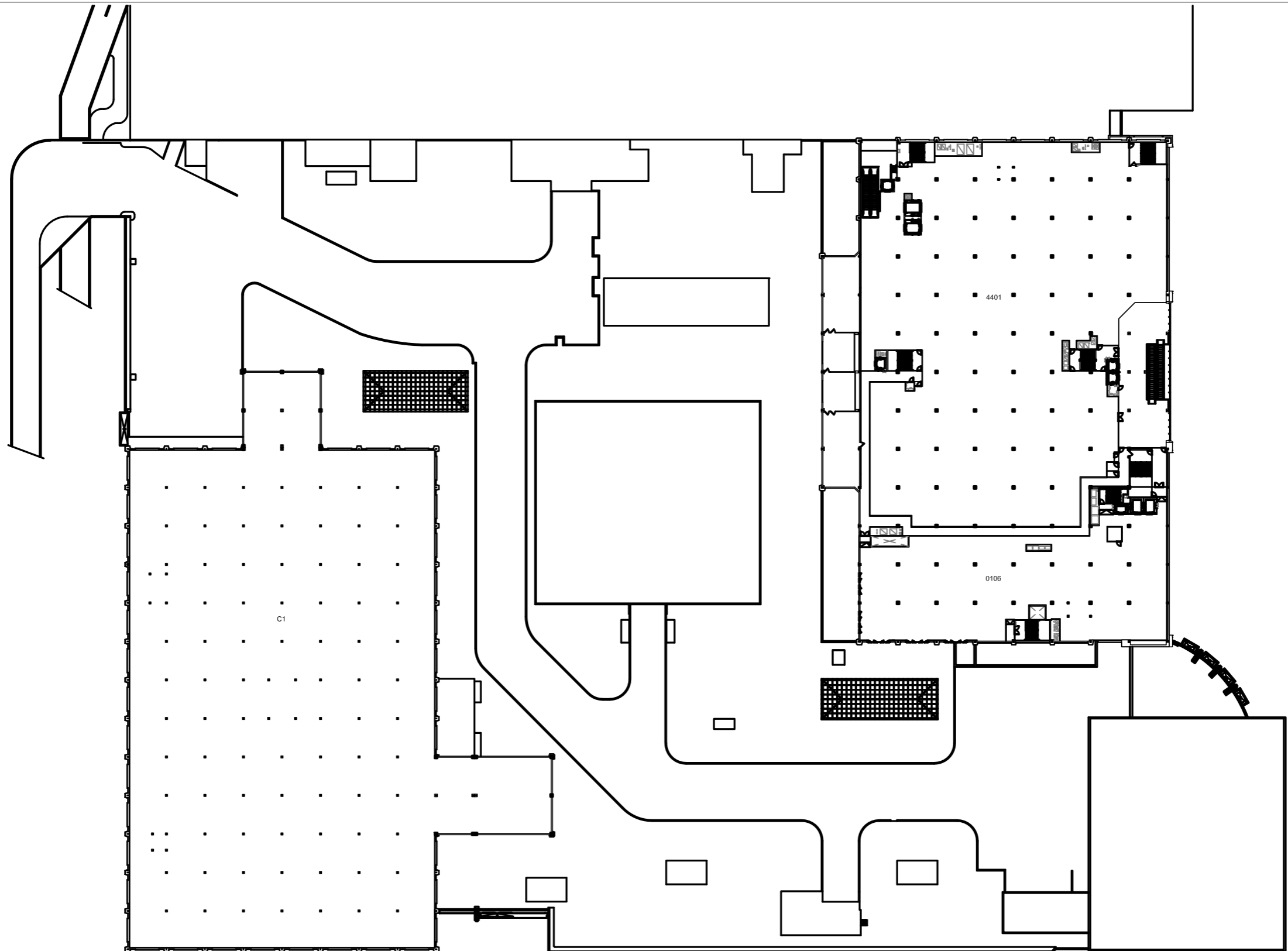

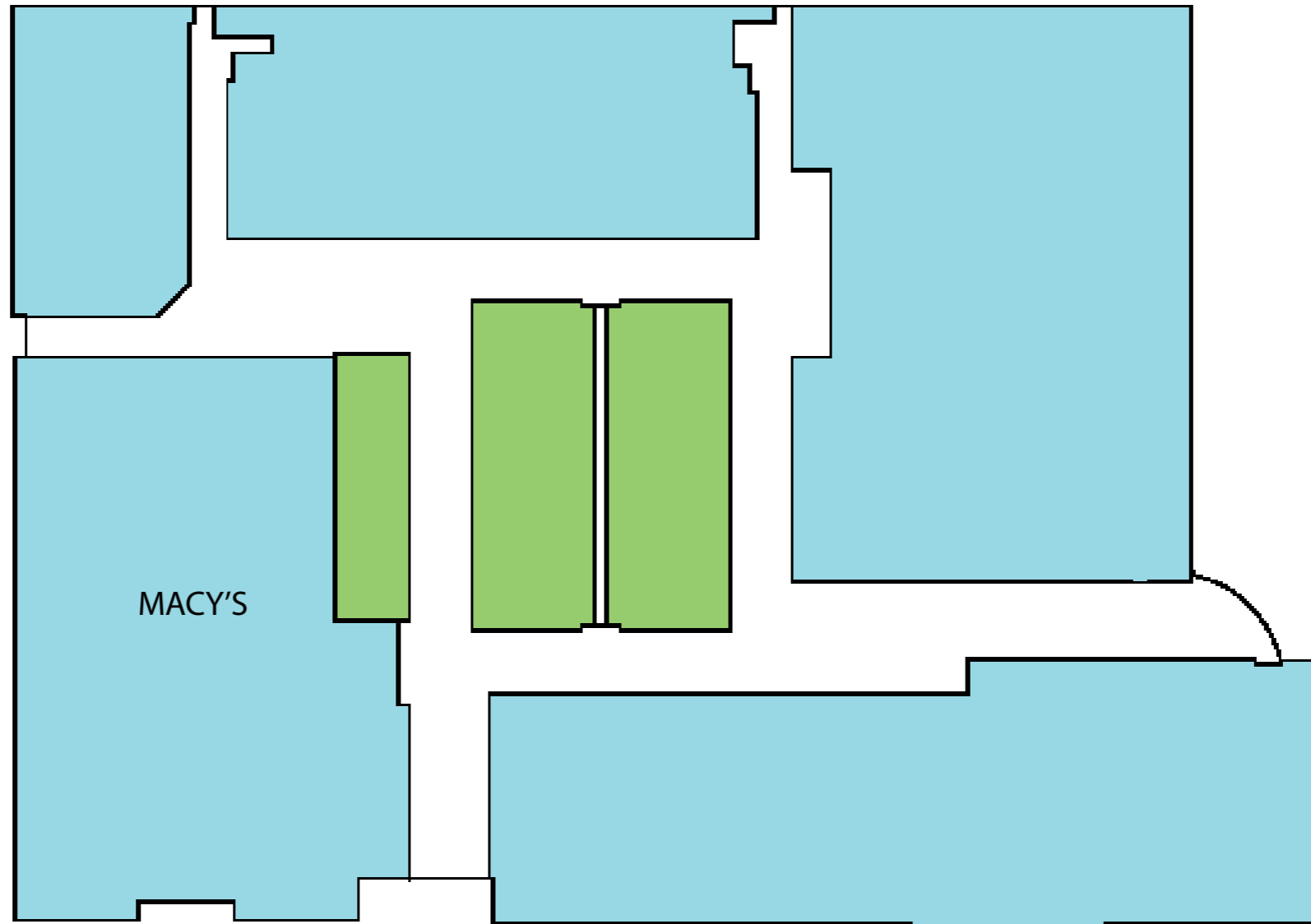

> LEVEL 1

PARKING GARAGE



FLATBUSH AVENUE

AVENUE U

-  CHILLED WATER & HOT WATER
-  CONDITIONED AIR

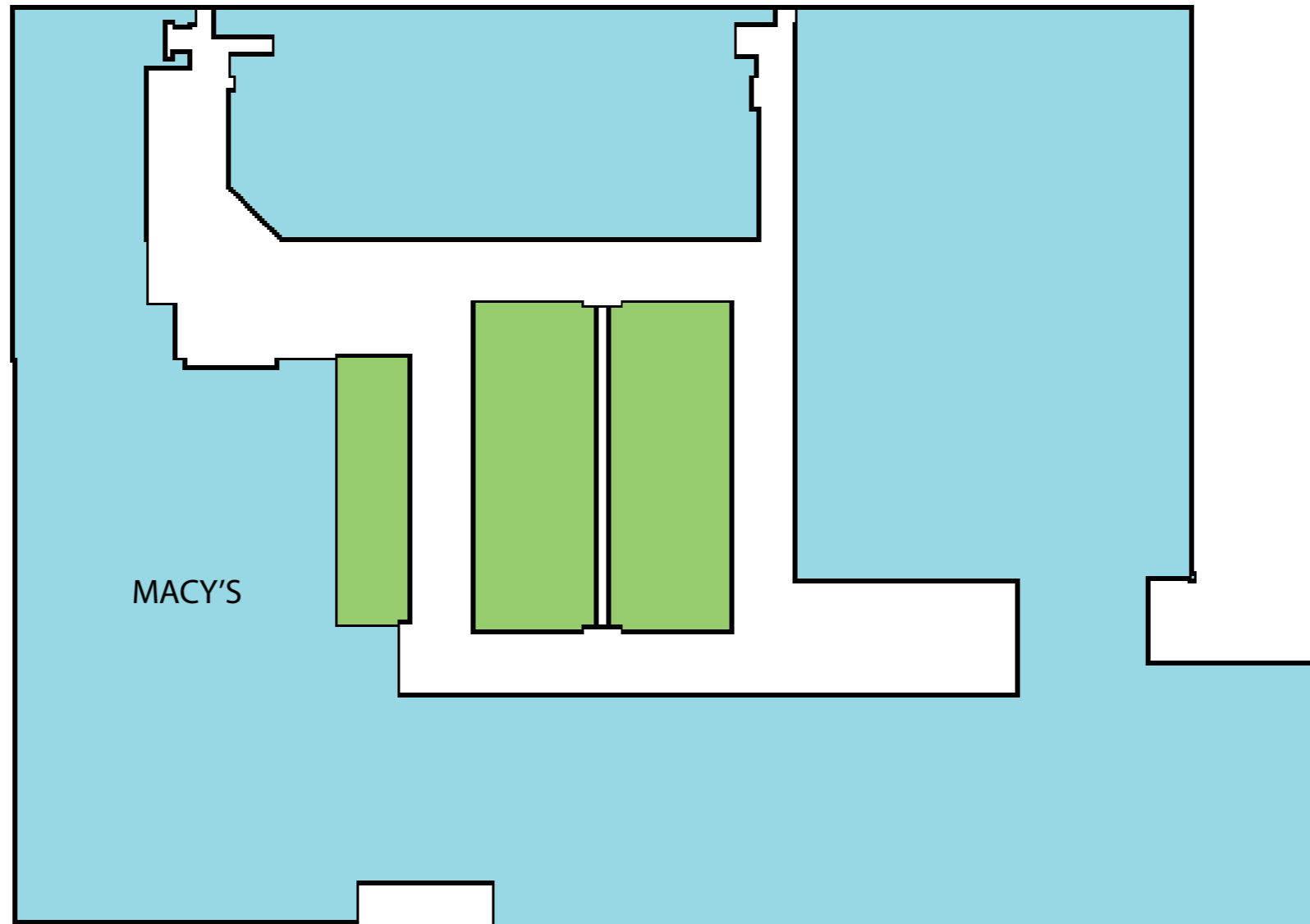

> LEVEL 2

PARKING GARAGE



FLATBUSH AVENUE

AVENUE U

-  CHILLED WATER & HOT WATER
-  CONDITIONED AIR

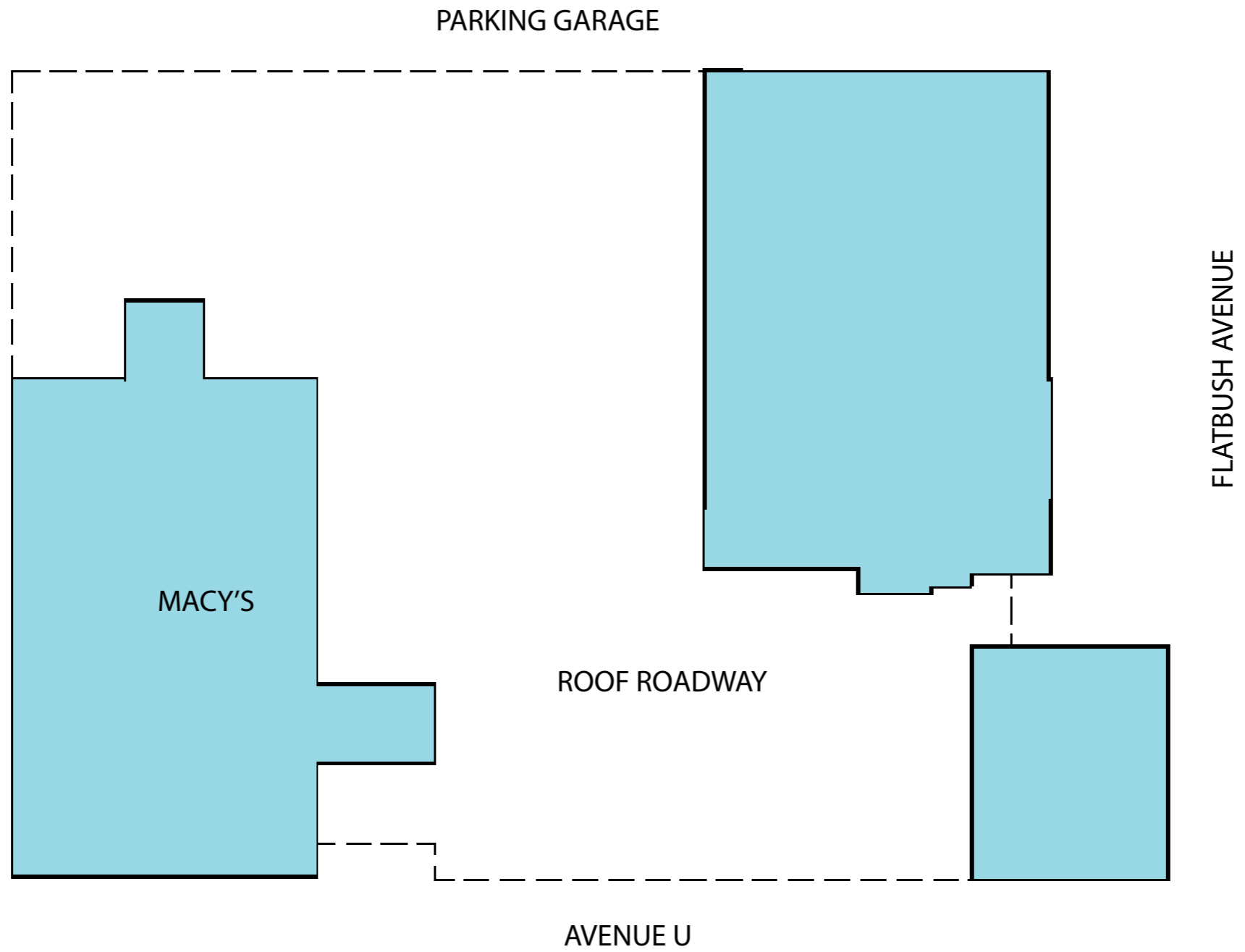

> LEVEL 3

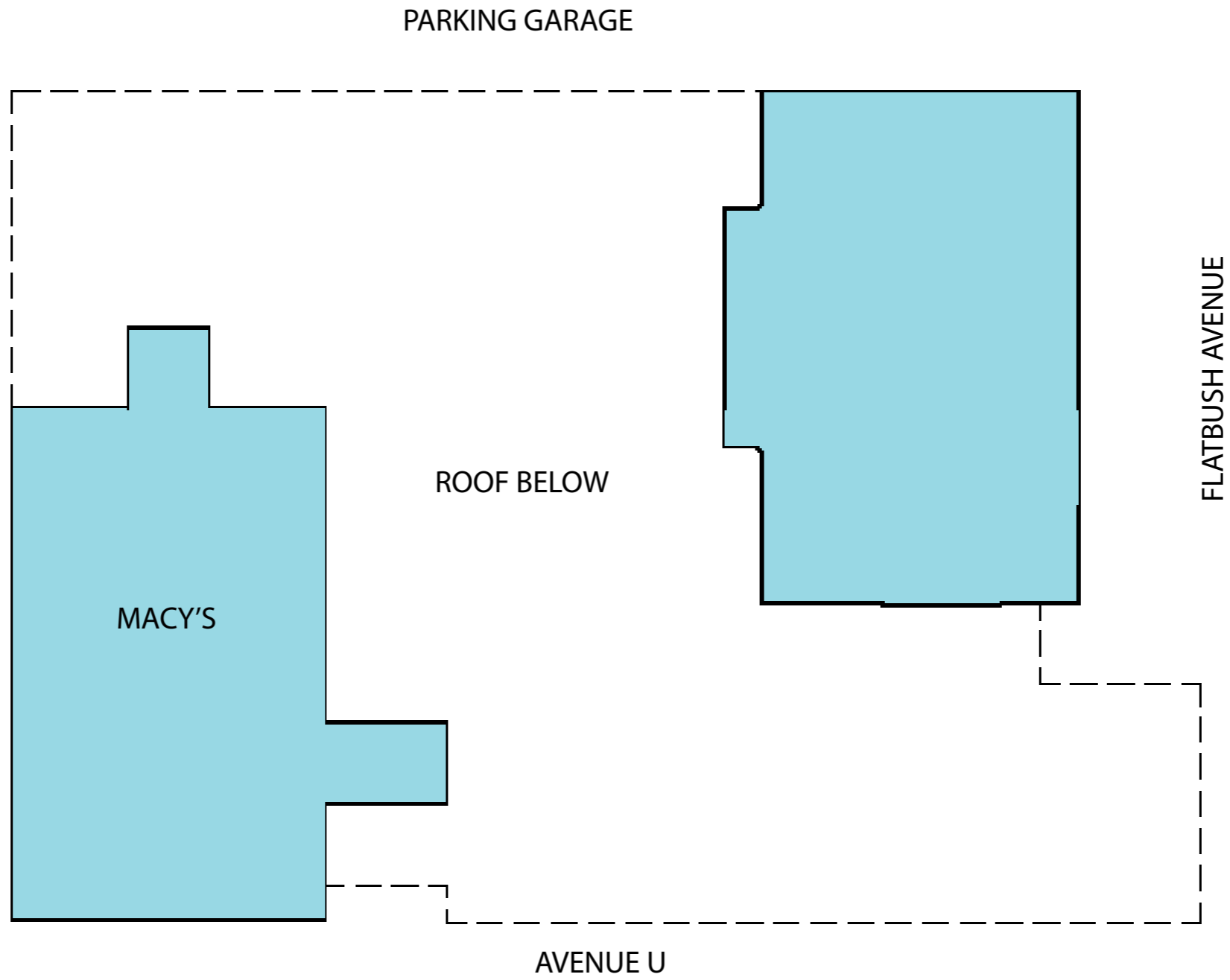

- CHILLED WATER & HOT WATER
- CONDITIONED AIR

> LEVEL 4



-  CHILLED WATER & HOT WATER
-  CONDITIONED AIR

DESIGN INSPIRATION CONTENT OVERVIEW

5.1

VISUAL CONCEPTS

GUIDE TO DIFFERENT AESTHETIC CONCEPTS ENCOURAGING VIBRANT STORE DESIGNS.

5.2

KEY DESIGN ELEMENTS

OVERVIEW OF THE CORE DESIGN ELEMENTS TO EMBRACE WHEN CREATING AN ENLIVENING RETAIL EXPERIENCE.

The vibrant character of great shopping destinations is comprised of exceptional storefronts with texture, color, lighting, graphics and merchandising enlivening the pedestrian experience.

Tenants are encouraged to express their individuality and their brand identity through excellent design by forward thinking design teams.



VISUAL CONCEPTS > OVERVIEW

- ARTISAN
- URBAN
- WHIMSICAL
- INVITING
- ARTSY
- THEATRICAL

This section highlights six design concepts encouraged by Macerich for Tenants looking for additional inspiration. Our Design team welcomes Tenants to engage in these concepts and invites open collaboration in an effort to create store designs that enhance the retail experience.

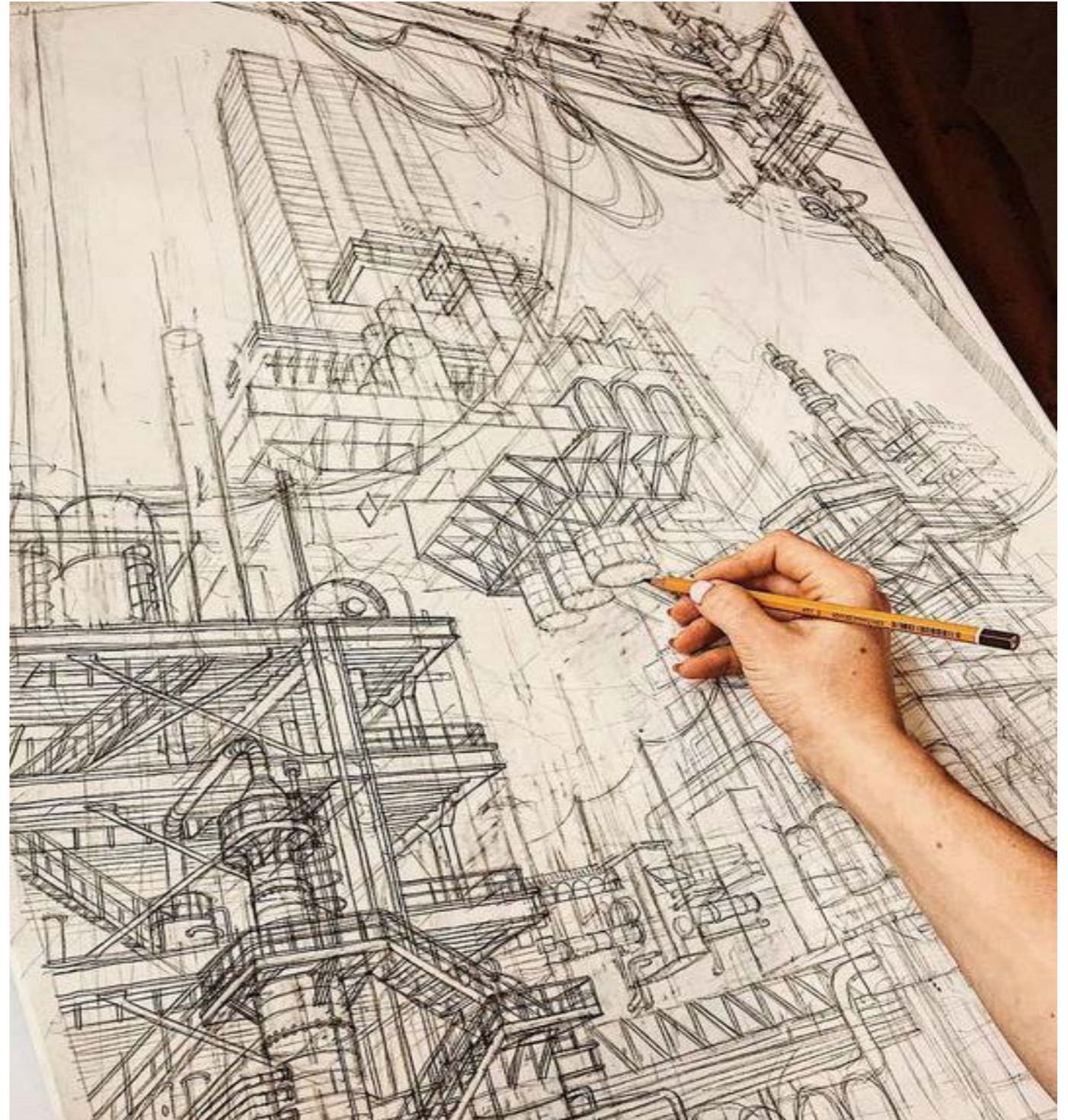

VISUAL CONCEPTS > ARTISAN

A R T I S A N
NATURAL, SOPHISTICATED, UNIQUE



> URBAN

URBAN

EDGY, FUNKY, STREET SAVVY STYLE, INDUSTRIAL

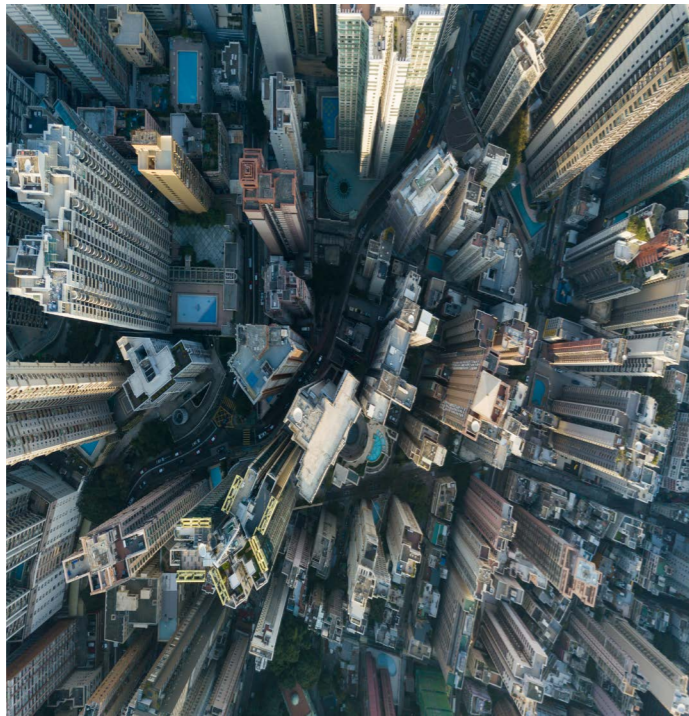

> WHIMSICAL

WHIMSICAL

UNEXPECTED, PLAYFUL, COLORFUL



> INVITING

INVITING
WARM, CALM, OPEN, SOFT



> ARTSY

ARTSY

QUIRKY, AVANT GARDE, SURPRISING



> THEATRICAL

T H E A T R I C A L
DRAMATIC, HIGH CONTRAST, MOVEMENT



KEY DESIGN ELEMENTS > BRANDING / VISUAL MERCHANDISING

Macerich embraces four key design elements to engage Customers and encourage Store traffic and sales. Strong use of textures, colors, lighting, graphics, and merchandising in these elements help draw Customers and invliven the pedestrian experience.

BRANDING

A brand is a name, term, design, symbol, color or some other feature that identifies a seller's product or services as distinct from those of other seller's.

Your branding can be communicated with signage, graphics, materials, shapes, colors, textures, patterns and the overall look and feel of your kiosk, to tell a story and create a lasting experience.



VISUAL MERCHANDISING

Strong visual presentation and merchandising are essential and integral components of retail design.

- Attempt to create triangular composition within style groups or color groups. (display in groups of three or five).
- Start with a center feature, (best sellers and hot items), and merchandise out symmetrically or asymmetrically in a balanced manner.



> LAYERING / TECH AND MEDIA

LAYERING

How can you make a wall / elevation into a canvas for communication to the Customer as they walk towards or by your store?

- Incorporating patterns and textures.
- Overlaying materials to create dimensionality.
- Molding shapes to create softness.
- Overlapping to create shadows and depth.



TECHNOLOGY AND MEDIA

Technology can enhance your online operation by transforming your retail space into a multifunctional one, that lends itself to being an in-store pick up location, payment booth or advertising billboard.

Integrating technology into your Store design can:

- Become an extension of you.
- Supplement your salesforce with interactive screens for ordering, self-design functions and more.
- Keep your business connected with your customer.
- Help you tell a story.
- Help make menu boards easier to update and better communicate your offerings to your Customer via LCD screen loops.

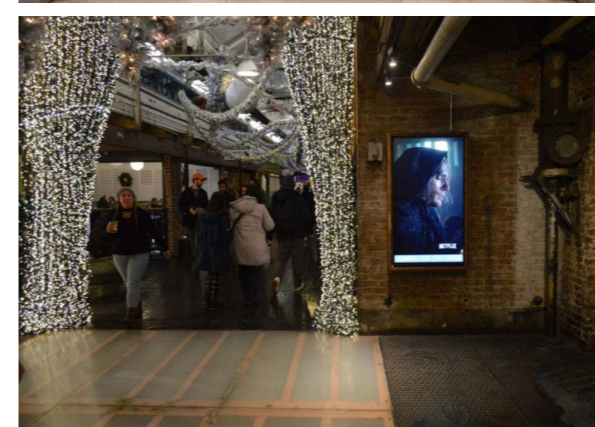

PROPERTY INFO CONTENT OVERVIEW

6.1

ADDRESS & HOURS

LOCATION AND SCHEDULE INFORMATION.

6.2

SITE PLAN

OVERVIEW MAP OF CENTER.

6.3

CONTACTS

MALL CONTACTS, REQUIRED CONTRACTORS, LOCAL MUNICIPALITIES, AND UTILITY CONTACT INFO.

6.4

CODES AND PERMITTING

OVERVIEW OF BUILDING CODE, CLASSIFICATIONS, AND LOCAL PERMITTING.

6.5

OPERATIONS AND UTILITIES

OVERVIEW OF CENTER OPERATIONS AND TYPICALLY AVAILABLE UTILITIES.

6.6

CONSTRUCTION

OVERVIEW OF CONSTRUCTION PROCEDURES.

The Property Info Criteria provides an overview of the Center's building classification, contacts, local permitting, and typically provided utilities.

It is important to note that the Contacts section includes the Center's required contractors. These contractors **must** be used during the design and buildout of your Store.



ADDRESS & HOURS

Kings Plaza is located at the corner of Flatbush Avenue and Avenue U in Brooklyn, New York. The Center is open 7 days a week. Open hours for individual restaurants and entertainment venues may vary.

Center Address

5100 Kings Plaza
Brooklyn, NY 11234

Center Hours

Monday - Friday: 10:00 AM - 9:30 PM

Saturday: 10:00 AM to 10:00 PM

Sunday: 11:00 AM to 8:00 PM



SITE PLAN

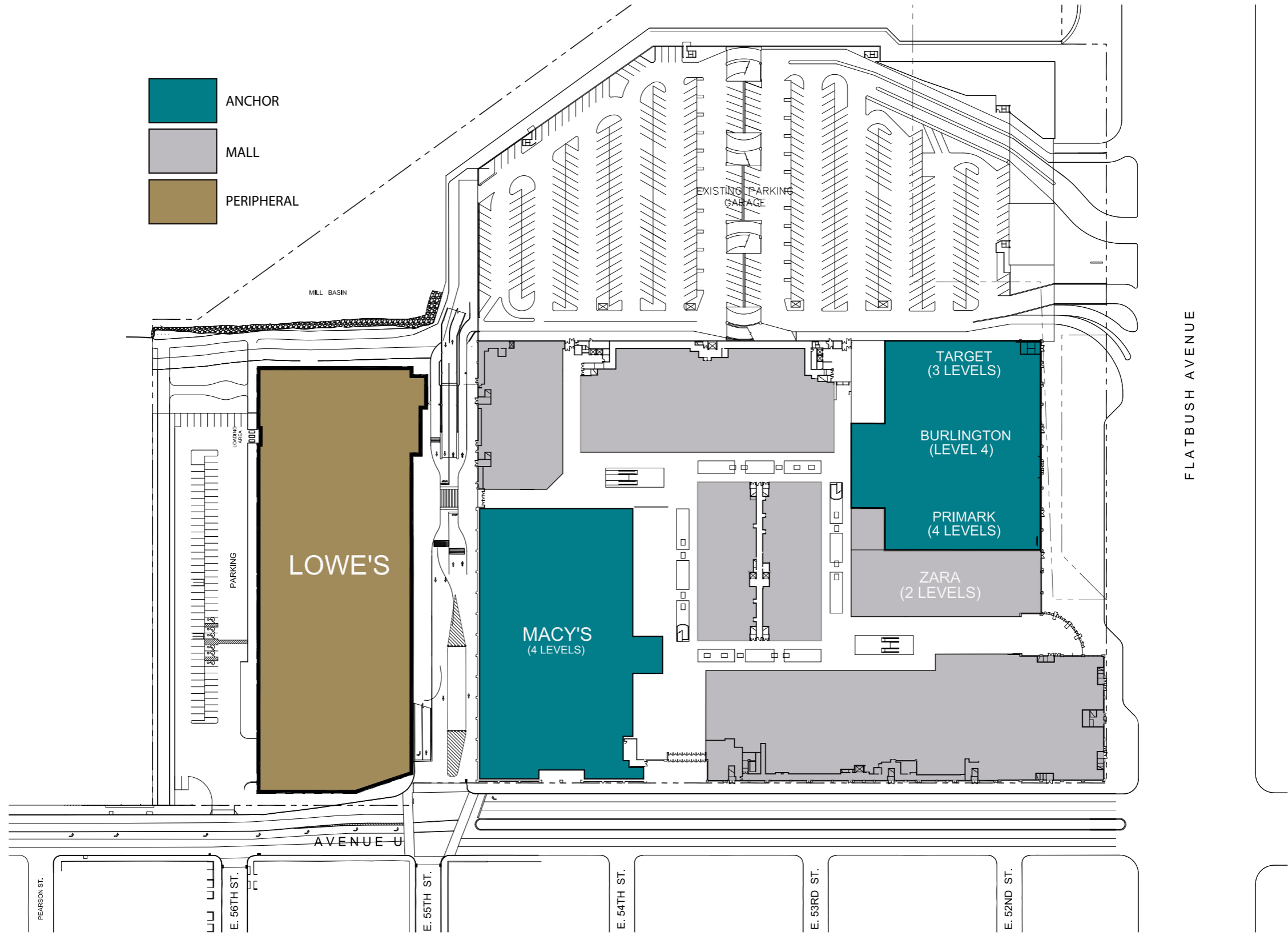

CONTACTS > PROPERTY TEAM / ENGINEERS OF RECORD

PROPERTY TEAM

The following points of contacts are available to discuss site details and procedures. The primary point of contact for inquiries is the Tenant Coordinator.

PROPERTY MANAGER

Emma Dawson

Phone: (718) 253-6844

emma.dawson@macerich.com

OPERATIONS MANAGER

Michael McCarthy

Phone: (718) 253-6844

michael.mccarthy@macerich.com

TENANT COORDINATION

Amy Christ

Phone: (585) 249-4413

amy.christ@macerich.com

LEASING

Rich Madramuthu

Phone: (212) 405-8800

richard.madramuthu@macerich.com

LANDLORD/OWNER

The MACERICH Company

401 Wilshire Blvd., Suite 700

Santa Monica, CA 90401

ENGINEERS OF RECORD

The following points of contact relate to the design and technical systems of the property. They are the designers on record for the property and offer detailed design insight into the building systems.

STRUCTURAL ENGINEER

Greg Matthews, PE, LEED AP

Vice President

Gannett Fleming

gmatthews@gfnet.com

MECHANICAL / ELECTRICAL / PLUMBING ENGINEER

DLB Associates - Jon Lanni

265 Industrial Way West

Eatontown, NJ

Phone: (732) 927-5006

jlanni@dbassociates.com

ARCHITECT

Gilligan & Bubnowski - Ted Bubnowski

246 Industrial Way West

Eatontown, NJ

Phone: (732) 460-1970

ted@gbanj.com

CONTACTS > REQUIRED CONTRACTORS

REQUIRED CONTRACTORS

The following points of contacts are the required contractors that must perform the construction for their related field and/or systems. These contractors are required since they have intimate knowledge of the property building systems and can properly interface Tenant systems with the base building infrastructure.

SPRINKLER CONTRACTORS

Pace Fire Protection - Peter Mirz
Phone: (212) 282-1638
pmirz@pacefireprotection.com

ELECTRIC METER INSTALLATION

Source One
Phone: (212) 612-7606
ajanes@S1inc.com

DATA PROVIDER / LOW VOLTAGE

Granite Grid
It is highly recommended to coordinate service install a minimum of 4 weeks in advance
Rob Norton
Phone: (781) 884-5545
rnorton@granitenet.com

FIRE ALARM DESIGN & EXPEDITING

ZS Engineering -Joseph Razza
Phone: (516) 328-3200
razza@zsengineering.com

FIRE ALARM CONTRACTOR (INSTALLATION & PROGRAMMING)

Mid City Electric
2190 McDonald Avenue
Brooklyn, NY 11223
(718) 333-2522
(347) 901-3946 Phone
jholzer@midcityec.com

ROOFING

US Allegro - Yuri Bogutskiy
Phone: (800) 876-4935
yuriy@usallegro.com

FIRE PROOFER (BUILDING STRUCTURAL STEEL)

Pal Environmental Safety Corp. - Beng Dangman
Phone: (718) 349-0900

PERMIT EXPEDITER

DOMANI Consulting or Green Light Expediting - Many Russell
Joseph Todisco and Alice Ramos Phone: (718) 514-7562
Phone: (516) 256-0317
jtodisco@DomaniConsultingInc.com
aramos@DomaniConsultingInc.com

BARRICADES

Boston Barricade
NY Local Team
Doug Guerra (GM)
772-257-7330
dguerra@bostonrs.com

CONTACTS > UTILITIES / LOCAL AGENCIES

UTILITIES

The following points of contact are required to set up utility accounts:

ELECTRICAL

Kings Plaza
Phone: (718)253-6844

DATA

Data is required to be set up through Granite Grid. Other service providers do not have a Right of Entry agreement and are not permitted.

Granite Grid - Rob Norton
Phone: (781) 884-5545
rnorton@granitenet.com

GAS

National Grid
One MetroTech Center
Brooklyn, NY 1120
Phone: (718) 403-2000

TRASH/REFUSE

Please contact Mall managment for more info: (718) 253-6842

WATER

Water is master metered by the Landlord.

LOCAL AGENCIES

The following points of contacts are the local agencies responsible for plan reviews and inspections:

BUILDING AND SAFETY

Department of Buildings
210 Joralemon Street
Brooklyn, NY 11201
Phone: (718) 802-3675

HEALTH DEPARTMENT

Health & Hospitals Central Office
2601 Ocean Parkway
Brooklyn, NY 11235
Phone: (718) 616-3000

FIRE DEPARTMENT

Fire Department Headquarters
250 Livingston Street
Brooklyn, NY 11201
Phone: (718) 694-2000

CODES AND PERMITTING

BUILDING CODE OVERVIEW

Kings Plaza offers spaces for retail, restaurants, and entertainment. Below are the pertinent property details related to local building codes. It is the sole responsibility of the Tenant's Architect, Engineers, Consultants, and Contractors to comply with all applicable federal, state, and local codes and ordinances for their occupancy type.

BUILDING TYPE

Type 2C Non-combustible

APPROVED OCCUPANCY TYPES

Group "M" for all stores. Group "A3" for all restaurants.

BUILDING AREA

Approxiamately 916,404 square feet.

CONSTRUCTION CLASSIFICATION

Covered center building Type II-B construction, mercantile, with business, storage.

APPLICABLE CODES

Currently adopted edition of the NYC Building code. It is the sole responsibility of the Tenant's Architect, Engineers, Consultants, and Contractors to comply with all applicable federal, state, and local codes and ordinances for their occupancy type.

PLEASE NOTE:

MERCHANDISE AND EMPLOYEE OCCUPANCY:

Please note that all inspections for trades and Life Safety must have proof of approval from the appropriate municipal governing authority (DOB & FDNY) prior to the arrival of merchandise and employees if a Certificate of Occupancy is NOT required.

PERMITTING

This center follows all requirements set by the NYC Department of Buildings (NYC DOB) and utilizes the DOB NOW on-line filing system linked here:

<https://www1.nyc.gov/site/buildings/index.page>

When applying for Permits, the address and BIN # must be filed as follows:

Block: 8470 **Lot:** 55

Vanity Address: 5100 Kings Plaza

AKA Address: 2515 Flatbush Avenue

BIN #: 3326830

The use of any other address or BIN # will result in DOB violations and Tenant will be responsible for any related charges to clear all violations prior to opening.

TRADE PERMITS

Individual Permits are required for Fire Alarm, Sprinkler & MEP work.

Each Permit must be signed by a Licensed Contractor and properly closed out to confirm the space meets all current NYC codes.

A copy of each closed permit will be required by the center in order for Tenant to open.

SIGN PERMITS

No Permit is required for interior signage at storefronts unless there is electrical work being done as well. In this case an electrical permit would be required. Unless specifically set forth in Tenant's lease, exterior signage is not allowed at this center.

CERTIFICATE OF OCCUPANCY

A new or amended Certificate of Occupancy (C of O) is required if construction will result in a change of use, egress, or occupancy to an existing space.

HEALTH PERMITS

Food Service Tenants are required to complete necessary training and certification with the NYC Health Academy where certification is required by law.

OPERATIONS AND UTILITIES

OPERATIONS

The following is a brief overview of the site infrastructure available during retail operations and construction.

PARKING

Contractor's may use the Center's parking garage, limited street parking is also available. Contractor personnel are to park only in areas designated by the Operations Manager or Center Manager. Loading bays and truck courts are to be used for loading and unloading only. Any vehicle left unattended will be towed away at Owner's expense. A fine will be imposed for each violation. Contractor personnel are to park only in areas designated by the Operations Manager or Center Manager.

TRASH

To be coordinated through Operations Manager during construction. The trash from any remodel or build-out is the responsibility of the general contractor. Dumpster fees and/or parking lot dumpster rental fee will be established and charged at the preconstruction meeting and charged accordingly.

DELIVERIES

All deliveries are to be made during off Mall hours. Any other delivery time must be pre-approved by the Operations Manager or Property Manager. The General Contractor must be on site to accept all deliveries. The loading dock is located on the Roof and is accessible by ramp located on Avenue U. Deliveries must be made through rear doors at all times. Exceptions are 4' x 12' drywall, long metal or wood pieces that cannot be moved through service corridors, or spaces without rear doors. These items must be delivered before 9:30 a.m. Contractor is responsible for cleaning up any tracked dust or debris on Mall floors after delivery is completed.

SITE UTILITIES AND SERVICES

The following is an overview of the utilities and services typically available for inline retail spaces. Please refer to lease language for any agreed upon changes that may overwrite these typical service provisions. It is the Tenant's responsibility to verify existing conditions and comply with all applicable codes and standards for all Technical systems.

ELECTRICITY

Tenant shell spaces typically provide conduit to a main power source.

Submeter to be installed by Landlord's required vendor. Contact mall's Operations Manager or Tenant Coordinator for more information.

DATA AND COMMUNICATIONS

Tenant shell spaces typically provide a conduit with pull string to nearest Granite rack.

Phone and internet services are provided on-site through Granite Grid.

Tenants must coordinate directly with Granite Grid to set up their data utility.

Other data providers do not have a right of access agreement and are not permitted access to the property.

SPRINKLER SYSTEM

Tenant shell spaces typically provide an automatic sprinkler system according to NFPA guidelines.

Tenants are responsible for contracting with the Landlord's required sprinkler vendor to adjust any existing grids, or install new if none exist, and tie into the main system.

CONSTRUCTION > PRE-CONSTRUCTION / CLOSE OUT

FIRE ALARM SYSTEM

Tenants are responsible for contracting with the Landlord's required fire alarm vendor to install all code-required alarm, horns, strobes, conduit within the Tenant's space to tie into the Landlord's main fire alarm panels.

WATER

Tenant shell spaces typically provide domestic cold water stubbed into the space. Size and location of the pipe varies per space. Spaces also typically provide a sanitary line stubbed into the space or located under the floor slab. Size and location of the line varied per space.

Water use is metered and charged by the Landlord for retail Tenants. A separate account with a water utility company is usually not required, unless Tenant is a food use.

HVAC

Tenants are required to furnish and install their own rooftop packaged units to provide HVAC to their space.

GAS

Gas utility is not available for in-line retailers.

The property does have a centralized gas service room available for food-use Tenants only.

CONSTRUCTION

The following is a brief overview of the construction process and requirements for a tenant build outs:

CONTRACTOR REQUIREMENTS AND WORKING ENVIRONMENT

Tenant, at Tenants sole cost and expense must ensure the following:

- All tradespersons entering the job site must be current members of a local building trades union and must, at all times, carry on their person such evidence of proof of their membership as may be required by the Landlord.
- All materials transported to and from the site must be done so by members of a current local building trades union.

PRE-CONSTRUCTION

Prior to any construction commencement, the contractor's site superintendent is required to meet with the Landlord to review property construction requirements, submit construction documentation, and provide payment for property construction fees.

Required pre-construction documents include:

- Landlord Approved Construction Drawings

- Contractors Rules & Regulations to be completed and signed in full
- Approved GC Certificate of Insurance
- A copy of the Building Permit issued by the City
- General Contractor's state license
- Construction Progress Schedule
- Subcontractor List (include associated trade, contact name and phone number)

The Landlord will send a Preparedness Letter detailing the fees required for collection prior to scheduling this pre-construction meeting.

[CONTRACTOR RULES AND REGULATIONS](#) are linked in the [ADDENDUM](#).

CLOSE OUT

At construction completion, the Landlord will meet with the superintendent to perform a punch list walkthrough. The created punch list is required to be completed to the Landlord's satisfaction in order to close out the construction project. All construction charges must be paid in full. A reference [PUNCH LIST](#) is linked in the [ADDENDUM](#).

To complete closeout, the following documents are required to be submitted:

- Copy of Certificate of Occupancy or equivalent and Proof of Passing Final Inspections.
- Final list of Subcontractors (please make any changes or additions from the list supplied at pre-con)
- Unconditional Lien Waivers from all contractors, subcontractors and materials and service suppliers.
- Notarized Affidavit from General Contractor stating that no liens exist as a result of Tenant's work.
- Notarized AIA documents G702 & G703 (if the job is \$100,000.00 or more) / General Contractors Final Billing
- AABC or NEBB Certified Air Balance Report
- As-Built Documents (record set of what was constructed at the site, including Architectural, Structural, Mechanical, Plumbing, Electrical, Fire Protection, etc.) Electronic (PDF) format preferred.

SUBMITTAL CRITERIA CONTENT OVERVIEW

7.1

CONSTRUCTION DRAWINGS

SUBMITTAL REQUIREMENTS FOR ARCHITECTURAL AND TECHNICAL DESIGN DOCUMENTS.

7.2

SIGNAGE DRAWINGS

SUBMITTAL REQUIREMENTS FOR PRIMARY AND SECONDARY STOREFRONT SIGN DESIGNS.

7.3

KIOSK DRAWINGS

SUBMITTAL REQUIREMENTS FOR ARCHITECTURAL AND TECHNICAL KIOSK DESIGN DOCUMENTS.

The Submittals Criteria highlights the Landlord review process and drawing submittal requirements to ensure a quick and smooth drawing review for your design and construction drawings.

Tenant construction and signage drawings must be reviewed and Approved by the Landlord before the drawings can be submitted for permit. Permits from the local Municipality are required for all incoming Tenant construction and signage.

It is always the Tenant's responsibility to ensure:

- Compliance with the Lease document.
- Field verification of conditions and dimensions.
- Discrepancies between the drawings and the as-build conditions.
- Coordination with trades to ensure compliance with all local and national codes.

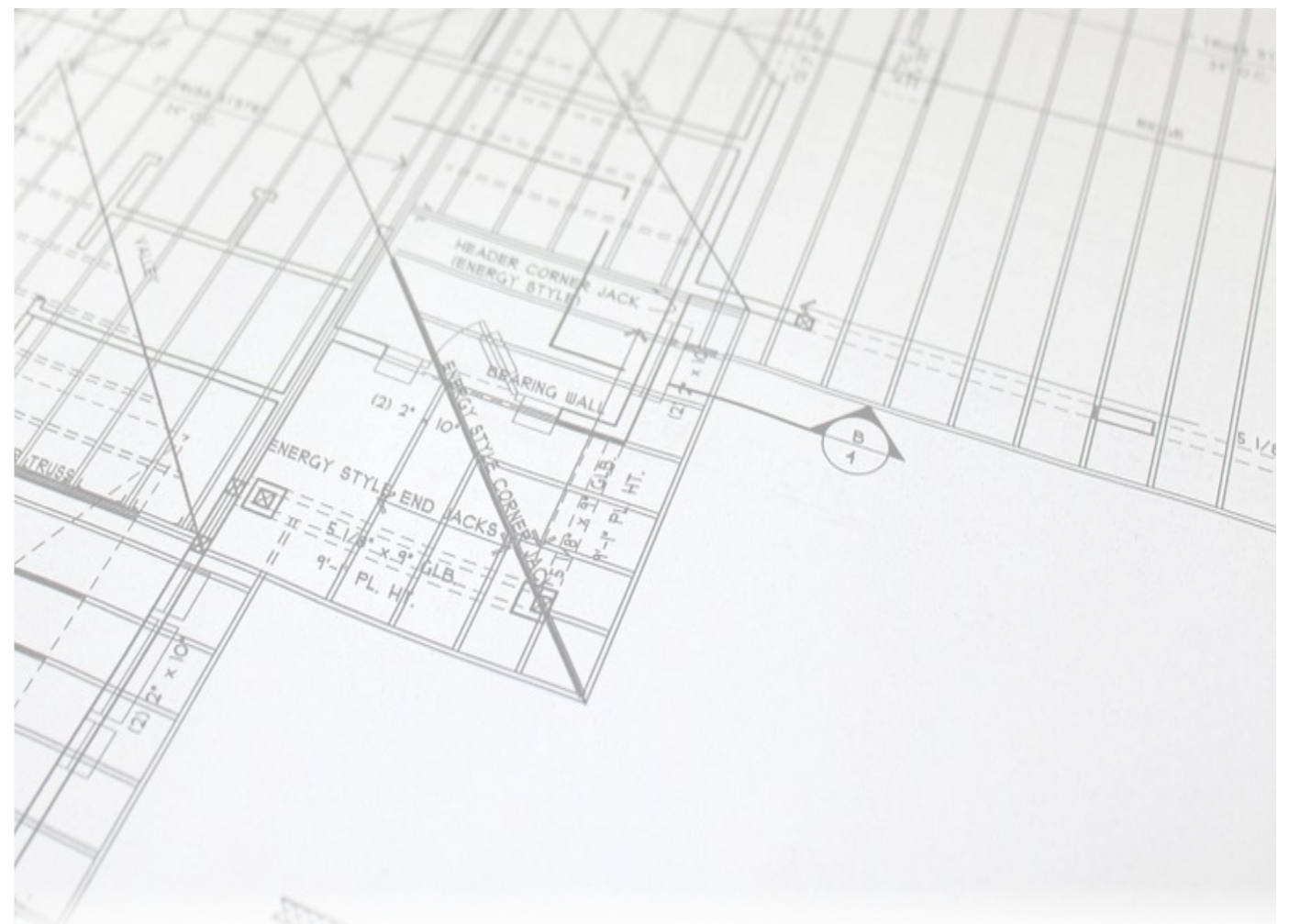

CONSTRUCTION DRAWINGS > PROCESS & TIMELINE

DRAWING REVIEW PROCESS

Drawing reviews are required to be submitted in two stages for Landlord review; Preliminary and final Construction Drawings. Preliminary drawings are required to ensure the design process moves quickly by ensuring that all Criteria requirements are understood and adopted early in the design. This helps ensure an expedited review of the final Construction Drawings.

REVIEW TIMELINE

Step	Action	Time Period
1	Tenant submits preliminary design.	Required 20 days after Lease Execution or 10 days following previous submittal disapproval.
2	Landlord Approved Preliminary Design.	15 days after confirmed completion of Step #1.
3	Tenant submits final construction drawings.	Required 20 days after Tenant Coordinator approval at Step #2.
4	Landlord Approves final documents.	15 days after completion of Step #3.
5	Tenant submits drawings for permit. (If applicable)	5 days after confirmed completion of Step #4.
6	Tenant responds to any requests from or comments by permitting jurisdiction.	5 days.
7	Upon permit review approval, Tenant pays all fees and logs out permit.	5 days.

> SUBMITTAL REQUIREMENTS > PRELIMINARY

PRELIMINARY DESIGN SUBMITTAL

The Preliminary Document review process will evaluate all the criteria discussed in this manual, including overall three-dimensional form, degree of design uniqueness and identity, use and detailing of materials, colors and lighting, and integration of signage and graphics.

Submittals are to provide the reviewer with a clear understanding of proposed design concepts.

The submission must be complete in order to fairly evaluate the proposal and prevent continuation of work on an unacceptable design.

Tenant shall submit to Landlord an electronic PDF files of the following:

- **Color and Material Sample Board**
Include actual samples of all Tenant colors and materials visible to the public, on a digital sample board. Clearly label all materials and reference to floor plan elevations.
- **Perspective and/or Photo Image(s)**
Colored perspective rendering and/or prototypical photo images of the proposed storefront, including graphics and signage.
- **Cover Sheet**
Include: Name of Tenant, name of Mall or Center, space number, Applicable Codes, Building Type and Occupancy Type, Leased square footage, and Key Plan
- **Floor Plan**
¼" Scale Minimum showing: Entire lease dimensioned space with room names, floor finishes, casework and fixture locations.
- **Reflected Ceiling Plan**
¼" Scale Minimum showing: Lighting design, including fixture types and locations, signage, access panels, Overhead projections such as light coves and fascia systems, and Entrance.
- **Sections**
1" Scale Minimum showing: Entry, Display windows and fascia, Sign integration into storefront design.
- **Storefront Elevations**
½ Scale Minimum showing: Exterior views - front and sides, Signs, graphics, logos.

A physical sample board is also required, mounted on foam core or card stock to be sent in coordination with your Tenant Coordinator.

> SUBMITTAL REQUIREMENTS > FINAL

FINAL DRAWING SUBMITTAL

After Preliminary Drawing Approval, it is critical to quickly complete and submit Final Construction Drawings for Landlord review.

If any questions arise from the Tenant's interpretation of the design and criteria information, the Tenant shall assume all responsibility for clarification by written request to the Tenant Coordinator. The Landlord plan review and approval process is independent of local permitting for construction. The Tenant is responsible for procurement and compliance with local, state and federal codes and requirements.

Tenant shall submit to Landlord an electronic PDF files of the following:

- **Responsibility Schedule**
Any work, which is the Landlord's responsibility, must be listed clearly on a responsibility schedule on the cover sheet.
- **Cover sheet**
Include a Key Plan, Name of Tenant, name of Mall or Center, space number and location leased premises within Mall or Center, Applicable codes, building type and occupancy type, Leased square footage, Responsibility schedule, and Drawing index.
- **Floor Plans**
¼" Scale Minimum showing: Entire lease space with room names, Floor finishes, casework and fixture locations, and Demolition plan.
- **Reflected Ceiling Plan**
¼" Scale Minimum showing: Complete lighting design, including fixture types and locations, signage, access panels, Overhead projections such as light coves and fascia system, Entry, Connection to Landlord's work, Tenant's framing and/or additional structure showing freestanding from Landlord's structure.
- **Sections**
1" Scale Minimum showing: Entry, Display windows and fascia, Sign integration into storefront design, Connection to Landlord's work, Tenant's framing and/or additional structure showing freestanding from Landlord's structure.
- **Interior Elevations**
¼" Scale Minimum showing: All sales floor interior views, Built-in casework, signage, and display systems.
- **Storefront Elevations**
½" Scale Minimum showing: Exterior views - front and sides, Signs, graphics, logos, Landlord neutral piers, Storefront finishes (to be referenced to finish schedule)
- **Architectural Details**
½" Scale Minimum.
- **Door Schedule**
Include floor transition details and anti-theft security system details.
- **Details, Catalogue Cut Sheets, and Fixture Finishes**
- **Finish & Color Schedule**
- **Include CAD/DWG drawing files as part of drawing submission including: Demo plan, Floor plan, MEP plans, and Life safety/ Egress Plans. Please include any background drawings that are necessary to view these files as a comprehensive whole.**

> SUBMITTAL REQUIREMENTS > FINAL ENGINEERING

FINAL DRAWING SUBMITTAL - ENGINEERING DRAWINGS

The Landlord does not review for mechanical, electrical, plumbing, or structural design, nor does the Landlord accept responsibility for the Tenant's adherence to governing codes.

Tenant shall submit to Landlord an electronic PDF files of the following engineering drawings included in the final drawing set:

I. MECHANICAL DESIGN DOCUMENTS

- Make, type, and performance of all equipment.
- Sign and seal by a Licensed Engineer in the state where the Shopping Center is located.
- Calculations showing the heating and cooling required, including transmission and ventilation losses in the space, and heat and cooling provided for the ventilation supply, and exhaust required for the space. Calculations must be performed in accordance with the latest ASHRAE standards and tabulated in a concise, orderly manner.
- Temperature control system data showing make, control, and energy management systems.
- Exhaust system layout including CFM and equipment specifications.
- Reflected ceiling plan showing HVAC equipment.
- Roof plan with equipment locations.
- Structural details for support of all rooftop equipment and equipment suspended from the steel structure.

II. PLUMBING DESIGN DOCUMENTS

- Make, type, and performance of all equipment.
- Sign and seal by a Licensed Engineer in the state where the Shopping Center is located.
- Complete plumbing system design and floor plan for the Tenant space including, but not limited to the toilets, sinks, urinals, drains, hot water heaters, water coolers, grease trap/interceptors and connections into existing water and sewer lines.
- Single line diagram.
- Fixture schedule.
- Water heater detail as applicable.
- Grease trap cut sheets as applicable.

III. FIRE PROTECTION / SMOKE EVACUATION DESIGN DOCUMENTS

- Reflected ceiling plan, with revised sprinkler head locations.
- Design must be City approved before construction

IV. ELECTRIC DESIGN DOCUMENTS

- Sign and seal by a Licensed Engineer in the state where the Shopping Center is located.
- Panel schedules, load calculations, and meter information, if applicable.
- Structural drawings for all equipment that will be suspended from the steel structure.
- Electrical load summary and Title 24 Energy Calculations (for State of California).
- Floor plan depicting equipment locations and branch circuitry.
- Reflected ceiling plan depicting the layout of light fixtures.
- System one line diagrams.
- Lighting fixture schedule.
- Equipment legend.

V. STRUCTURAL DESIGN DOCUMENTS

- Design elements affecting the structure of the base building.
- Alterations, additions, modifications and reinforcements to the base building which shall be required to accommodate Tenant's Work.
- All calculations & details (Include ICBO numbers on all framing details, Seismic bracing details for State of California.)
- All forms required by governmental agencies and Governmental Regulations, fully and properly completed and executed by Tenant.
- Partial structural framing plan showing existing conditions for new and existing rooftop installations and proposed reinforcement, which shall be accompanied by structural engineers' calculations, drawn on a scale of $\frac{1}{2}''=1'0''$.
- Ceiling, soffits, storefront attachment details to existing base building.
- A letter from a state-registered structural engineer certifying that all new equipment and design elements serving the Premises are adequately supported to carry the new load.

SIGNAGE DRAWINGS > PROCESS & TIMELINE

DRAWING REVIEW PROCESS

Sign drawing reviews are required to be submitted in two stages for Landlord review; Preliminary and final Construction Drawings. Preliminary drawings are required to ensure the design process moves quickly by ensuring that all Criteria requirements are understood and adopted early in the design. This helps ensure an expedited review of the final Construction Drawings.

REVIEW TIMELINE

Step	Action	Time Period
1	Tenant submits preliminary design.	Required 20 days after Lease Execution or 10 days following previous submittal disapproval.
2	Landlord Approved Preliminary Design.	15 days after confirmed completion of Step #1.
3	Tenant submits final construction drawings.	Required 20 days after Tenant Coordinator approval at Step #2.
4	Landlord Approves final documents.	15 days after completion of Step #3.
5	Tenant submits drawings for permit.	5 days after confirmed completion of Step #4.

> SUBMITTAL REQUIREMENTS > PRELIMINARY, FINAL

PRELIMINARY DESIGN SUBMITTAL

The Preliminary Document review is intended to acquaint the Landlord with the Tenant's signage design intent.

Submittals are to provide the reviewer with a clear understanding of proposed design concepts.

The submission must be complete in order to fairly evaluate the proposal and prevent continuation of work on an unacceptable design.

Tenant's licensed sign contractor shall submit to the Center's Tenant Coordinator electronic PDF files of the following:

- **Perspective and/or Photo Image(s)**
Colored perspective rendering and/or prototypical photo images of the proposed storefront, including graphics and signage.
- **Storefront Elevations**
½ Scale Minimum showing: Exterior views - front and sides, Signs, graphics, and logos highlighting sign dimensions and materials.

FINAL DRAWING SUBMITTAL

After Preliminary Drawing Approval, it is critical to quickly complete and submit Final Construction Drawings for Landlord review.

If any questions arise from the Tenant's interpretation of the design and criteria information, the Tenant shall assume all responsibility for clarification by written request to the Tenant Coordinator. The Landlord plan review and approval process is independent of local permitting for construction. The Tenant is responsible for procurement and compliance with local, state and federal codes and requirements.

The Landlord does not accept responsibility for the Tenant's adherence to governing codes or verification of job site conditions.

Tenant's licensed sign contractor shall submit to the Center's Tenant Coordinator electronic PDF files of the following:

- Elevation of the storefront including signage and graphics; showing all doors, architectural features, etc., and fully detailed/dimensioned sections and details through the storefront.
- These fully detailed and dimensioned drawings shall be drawn to scale as noted:
 - Storefront Plan, Elevation and Sectional views at 1/2 inch scale.
 - Details of the Signage at 1/2 inch scale or larger.
 - Storefront Signage at 1/2 inch scale.
- Letter style and typeface specifics.
- Color and finish qualities of all portions of signage.
- Material specifications and thickness.
- Transformer specifications, including input and output voltage of transformers. PK housing, (or other UL approved insulating sleeve approved by Landlord and local building codes), is required for all through wall penetrations and must be indicated on the sign shop drawings. Wiring specifications.
- Locations of service switches, access panels and transformers. NONE of these items shall be visible to the public from any portion of the Mall.
- Neon tube specifications, including color and dimension (in mm) of tubes to be used.
- Type of lamps.
- Mounting hardware.

KIOSK DRAWINGS > PROCESS & TIMELINE

DRAWING REVIEW PROCESS

Kiosk drawing reviews are required to be submitted in two stages for Landlord review; Preliminary and final Construction Drawings. Preliminary drawings are required to ensure the design process moves quickly by ensuring that all Criteria requirements are understood and adopted early in the design. This helps ensure an expedited review of the final Construction Drawings.

REVIEW TIMELINE

Step	Action	Time Period
1	Tenant submits preliminary design.	Required 20 days after Lease Execution or 10 days following previous submittal disapproval.
2	Landlord Approved Preliminary Design.	15 days after confirmed completion of Step #1.
3	Tenant submits final construction drawings.	Required 20 days after Tenant Coordinator approval at Step #2.
4	Landlord Approves final documents.	15 days after completion of Step #3.
5	Tenant submits drawings for permit.	5 days after confirmed completion of Step #4.

> SUBMITTAL REQUIREMENTS > PRELIMINARY, FINAL

PRELIMINARY DESIGN SUBMITTAL

The Preliminary Document review is intended to acquaint the Landlord with the Tenant's signage design intent.

Submittals are to provide the reviewer with a clear understanding of proposed design concepts.

The submission must be complete in order to fairly evaluate the proposal and prevent continuation of work on an unacceptable design.

Tenant's licensed architect shall submit to Landlord an electronic PDF files sized 24" x 36" format of the following on:

- Colored perspective rendering and/or prototypical photo images of the proposed kiosk, including graphics and signage.
- A material sample board, (8-1/2" x 11" minimum), clearly noting the Tenant name and Mall name.
- A floor plan.
- Sections and elevations of the kiosk.

FINAL DRAWING SUBMITTAL

After Preliminary Drawing Approval, it is critical to quickly complete and submit Final Construction Drawings for Landlord review.

If any questions arise from the Tenant's interpretation of the design and criteria information, the Tenant shall assume all responsibility for clarification by written request to the Tenant Coordinator. The Landlord plan review and approval process is independent of local permitting for construction. The Tenant is responsible for procurement and compliance with local, state and federal codes and requirements.

The Landlord does not accept responsibility for the Tenant's adherence to governing codes or verification of job site conditions.

Tenant's licensed architect shall submit to Landlord an electronic PDF files sized 24" x 36" format of the following on:

- A cover sheet including a vicinity map, location map, (LOD), all code compliance notes as required by the city.
- Floor plan detailed and scaled, showing all components, counters, cash wraps, islands, condiment area layout, partitions etc.
- All finishes and fixtures with complete schedules and keyed plans and elevations.
- Details and sections of each side as well as the pylon, counter edge, millwork, toe kick, raised flooring, wall caps, special conditions etc.
- All interior and exterior elevations, with sign locations and dimensions.
- Anything necessary to describe structures or design features, not depicted or easily understood.
- Electrical drawings including a plan layout.
- Plumbing drawings, if applicable.
- Equipment schedule and finish schedule.
- Sign shop drawings, with plan, elevations, sections, materials and details.

ADDENDUM LINKS

This Addendum contains links to supplemental documents of specific requirements and information. These documents are considered part of the Tenant Criteria Package. Clicking the links below will navigate to the described documents. It is the responsibility of the Tenant, its contractors, subcontractors, architects, engineers, employees, and agents to comply with terms of the Tenant Criteria, Addendum included.

GLOSSARY

I. [GLOSSARY OF TERMS](#)

Defines commonly used terms for clarity.

DESIGN ADDENDUM

I. [MACERICH SUSTAINABILITY HANDBOOK](#)

Guide to encourage energy efficient, sustainable design.

II. [SPECIALTY LEASING CRITERIA](#)

Design requirements for temporary Tenant's buildout and signage.

III. [SECOND LEVEL TILE PROTOCOL](#)

Specific protocol for designing and installing Tile on the Second Level.

BARRICADE ADDENDUM

I. [BARRICADE GUIDELINES](#)

Guide to installing and activating construction barricades with graphics.

CONSTRUCTION ADDENDUM

I. [CONTRACTOR RULES AND REGULATIONS](#)

Document detailing the rules and regulations Tenant contractors must adhere to during their construction. This document must be reviewed and signed by the Site Superintendent overseeing the Tenant build out.

II. [HOT WORK PERMIT](#)

Required form to submit when construction required hot work.

III. [PUNCH LIST](#)

Reference Landlord Punchlist that that Landlord will use to inspect and confirm completion of Tenant construction.

IV. [CLOSE OUT REQUIREMENTS](#)

List of required documents and samples to submit in order to fully close out your project.