

ARCHITECTURAL DESIGN CRITERIA

FASHION OUTLETS OF NIAGARA FALLS



MACERICH® THE PLACE TO SHOP

ADDENDUM LOG

November, 2011

Updated to current layout

April, 2012

Updated per TC

September, 2013

Added Storefront Requirements images (a6-a17)

Updated Floor Tile Finish language (a18)

Added Neutral Pier Detail images (a23-a25)

October, 2013

Updated to include Reveal details per TC request

November, 2013

Updated Neutral Pier details per TC (a23-a25)

January, 2014

Revised Walls/Partitions content (a30)

December, 2014

Addition of LED lighting in public Tenant area shall be recessed (a30)

February, 2015

Revised waterproof membrane beneath the finish floor surface up to 4". (a31)

April, 2015

All storefront metal panels must meet LL requirements (this note must appear on final drawing set.) (a26)

July 2015

Above normal sound levels must provide sound isolation (a29)

September 2017

Updated layout

FASHION OUTLETS OF NIAGARA FALLS

PLEASE VISIT
WWW.MACERICH.COM

TO VIEW
PLAN SUBMITTAL & APPROVAL
PROCEDURES
and CONTRACTOR RULES &
REGULATIONS

TABLE OF CONTENTS

ARCHITECTURAL DESIGN CRITERIA

General Storefront Requirements	a4-a5
Zone Plans	a6-a13
Typical Elevations / Sections	a14-a15
Existing Conditions Diagram	a16-a17
Storefront Design Criteria	a18-a21
Windows & Glazing	a18-a19
Awning Type, Awning Signage	
Awning Logos	a20
Overhangs, Umbrellas	a21
Neutral Pier Details	a22-a25
Materials	a26-a28
General Material Requirements, Metals, Stone	a26
Wood, Tile, Pre-cast Stone and Concrete, Plaster, Faux Finishes, Painted Surfaces	a27
Prohibited Materials	a28
Interiors	a29-a31
DCA, Ceilings	a29
Lighting, Walls/Partitions	a30
Floor and Wall Base, Toilet Room Requirements	a31

GENERAL DESIGN CRITERIA

FASHION OUTLETS OF NIAGARA FALLS

The Landlord's goal is to create a significant destination in the retail world. The physical environment is one means to attain the goal. The Design Criteria for Tenant Improvements establishes the Landlord's baseline or minimum standard for quality and construction of retail spaces. The physical characteristics are guided by a design concept that is open, clean, uncluttered, and simple in execution.

The Tenant should respond creatively to design challenges and through the submittal process present its solutions to the Landlord. While the Design Criteria is a framework and not intended for strict compliance, the Landlord shall interpret and enforce the Design Criteria in its reviews and keep the Tenant within reasonable limits of its intent.

THE TENANT MUST VERIFY ALL CONDITIONS IN THE FIELD. Text and illustrations of the Design Criteria are to aid the Tenant conceptually in the design of the Tenant improvements. The actual configuration of the storefront or base building may vary.

A. Concept Development

The Tenant must develop a total store design concept that coordinates storefront, signs, interior design, lighting, and visual display. Tenants are encouraged to build this total design concept around unique aspects or themes of their business operation or product. The customer experience must be enhanced by a one of a kind environment, showcasing superior merchandising skills, and excellence in customer service.

Each Tenant is to express a creative and individual look all its own. National and regional chain stores are to creatively adapt their prototype design concepts to meet the specific requirements of Fashion Outlets of Niagara Falls. Tenants are not to copy or mimic the Landlord's architecture, materials, or finishes as a means to 'fit in'. The Landlord's construction at the storefront is a neutral framework for Tenant expression.

B. Execution of Design

- The Tenant, Tenant's Architect, and Tenant's Contractor assume the following obligations relative to the Design Criteria.
- Address the intent of the Design Criteria in concept and execution.
- Determine and respond to the actual physical conditions specific to the Tenant's location.
- Maintain the high standards of quality exemplified by the Landlord's own design and construction.
- Assure high quality in Tenant design, materials and finishes, and workmanship.
- Acknowledge that the Landlord is the final arbiter of the requirements of the Criteria.
- Be familiar and comply with local and national building codes in execution of design and construction.

GENERAL STOREFRONT REQUIREMENTS

FASHION OUTLETS OF NIAGARA FALLS

The following criteria apply:

- The Tenant storefront is the entire Tenant construction including the entry, entry door, and window configuration and glazing located at the Lease Line. The Lease Outline Drawing locates the Lease Line relative to the permanent building structure. The bounds of the new Tenant storefront are strictly defined regarding height, neutral piers, pop-outs, and attachments to the storefront beyond the Lease Line for each type.
 - All storefronts shall be designed, fabricated, and installed by the Tenant solely at the Tenant's expense. The design of the Tenant storefront must comply with local codes and the minimum design requirements set forth by the Landlord's criteria for all storefront types.
 - All storefront designs and plans are subject to Landlord approval. The overall image should be well coordinated, fully integrating components such as entries, displays and signage.
 - Storefronts must be of the highest caliber: expressing state of the art and material quality and meeting or exceeding the very best examples. To achieve this goal, Tenants shall be required to select an Architect who has experience in retail Tenant design.
1. The Tenant may not modify any Landlord construction in the execution of the Tenant storefront unless specifically approved during the design review process. The Tenant is required to restore the base building construction and finishes when damaged by the Tenant.
 2. The Tenant shall protect and preserve existing Landlord finishes and construction that surround the Tenant storefront.
 3. The Tenant should never mimic or copy the Landlord materials and finishes at its own storefront.
 4. The underside of the bulkhead is the upper limit of the Tenant's storefront glass. The drywall bulkhead shall return to the Tenant storefront system and shall be painted to match the Landlord's fascia.
 5. All storefront construction shall be self supporting from the floor and independent of the building fascia and bulkhead structure. Storefronts may be braced to the overhead structure within the Tenant space. A minimum of 60% of the storefront is to be display windows.
 6. Three-dimensional articulations in both storefront plan and height are required for all storefronts in the new Tenant areas.
 7. Tenants will provide a flush transition between their flooring and the Mall flooring.
 8. Storefronts visible from the upper level must take special care that the tops of storefronts are finished to match the storefront design. There are to be no exposed conduits, raceways, access panels or equipment visible from upper level. In addition, all surfaces of any visible projections must also be finished to match.
 9. The underside of the entry portal soffit shall be finished to match the storefront. Gypsum board will not be permitted.
 10. Stores less than 800 square feet shall be required to have durable floors and gypsum board ceilings throughout the sales area.
 11. Pedestal type security system not allowed. Tenant can specify concealed system. Tenant to submit specifications to Landlord for approval.
 12. Entry doors are required and are to be a minimum of 9'-0" in height. All other doors are to be hinged or pivot-type doors. Doors are suggested to be the height of the glazed storefront, where possible. Maximum opening width allowed for storefront entrance is 8'-0".
 13. Storefront Condition A T/Storefront 15'-0" GYP BD ceiling and Storefront B T/Storefront 18'-0" Clerestory. Refer to pages a6 - a17 for Zone Plan, Mall Interior Rendering, Typical Elevation/Sections and Reflective Ceiling Plan.
 14. Mezzanines are not permitted in any area of this project.

ZONE PLAN

FASHION OUTLETS OF NIAGARA FALLS

STOREFRONT CONDITION A
T/STOREFRONT 15'-0"
GYP BD CEILING



STOREFRONT CONDITION B
T/STOREFRONT 18'-0"
CLERESTORY

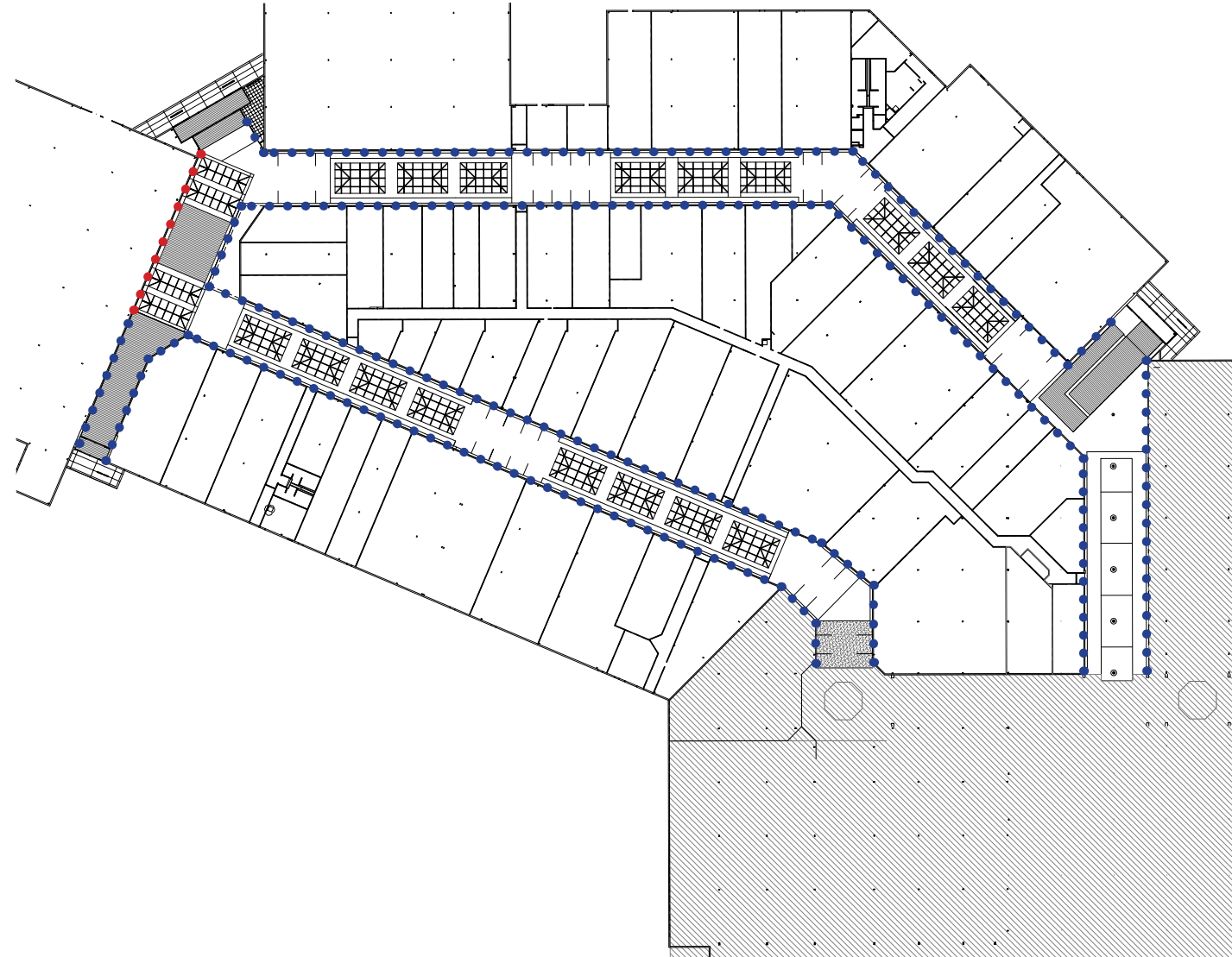

FLOOR PLAN

FASHION OUTLETS OF NIAGARA FALLS

CONTINUED

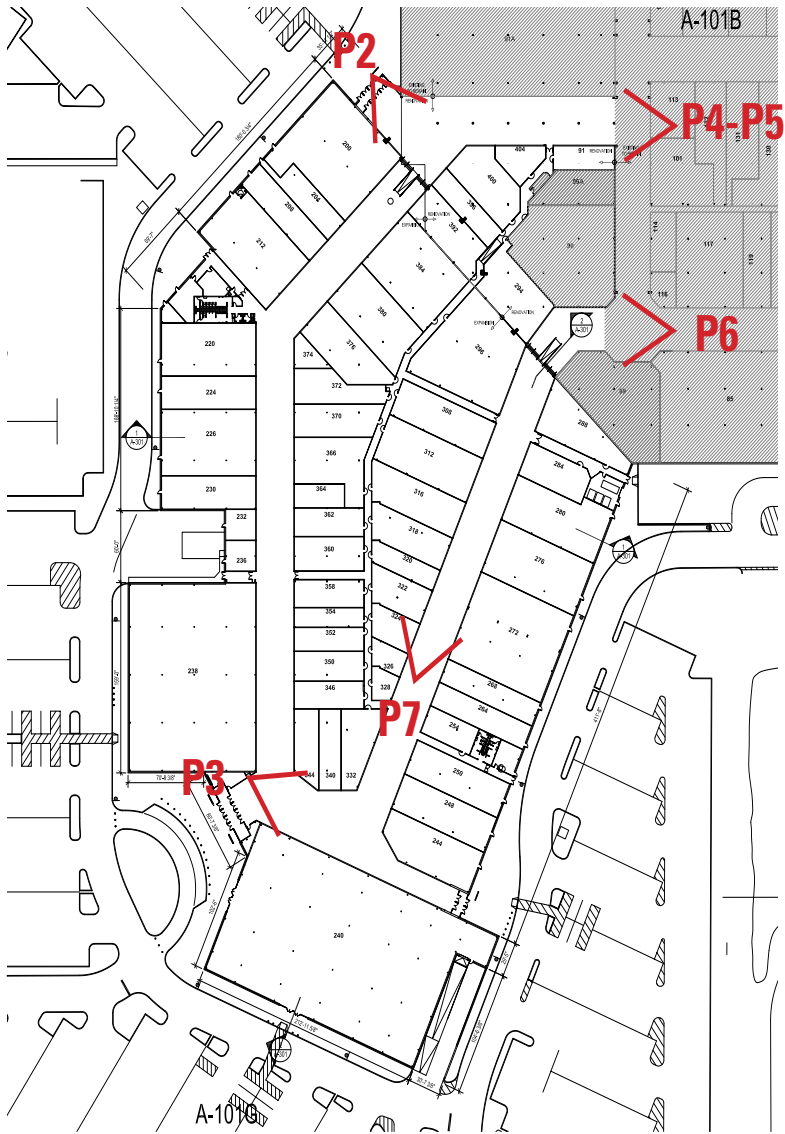

NORTHWEST ENTRY (P2)

FASHION OUTLETS OF NIAGARA FALLS

CONTINUED

NORTHWEST ENTRY (P2)

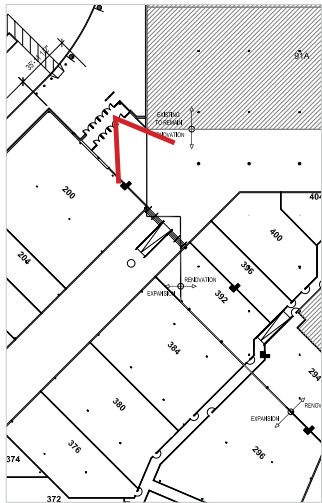

SAKS' COURT ENTRY (P3)

FASHION OUTLETS OF NIAGARA FALLS

CONTINUED

SAKS' COURT ENTRY (P3)



TRANSITION (P4)

FASHION OUTLETS OF NIAGARA FALLS

CONTINUED

TRANSITION (P4)

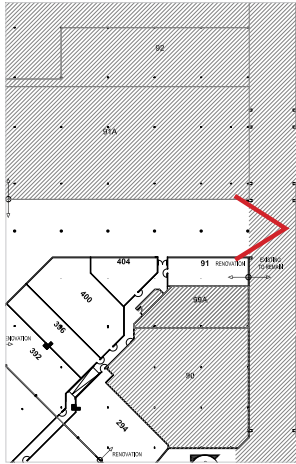

TRANSITION (P5)

FASHION OUTLETS OF NIAGARA FALLS

CONTINUED

TRANSITION (P5)

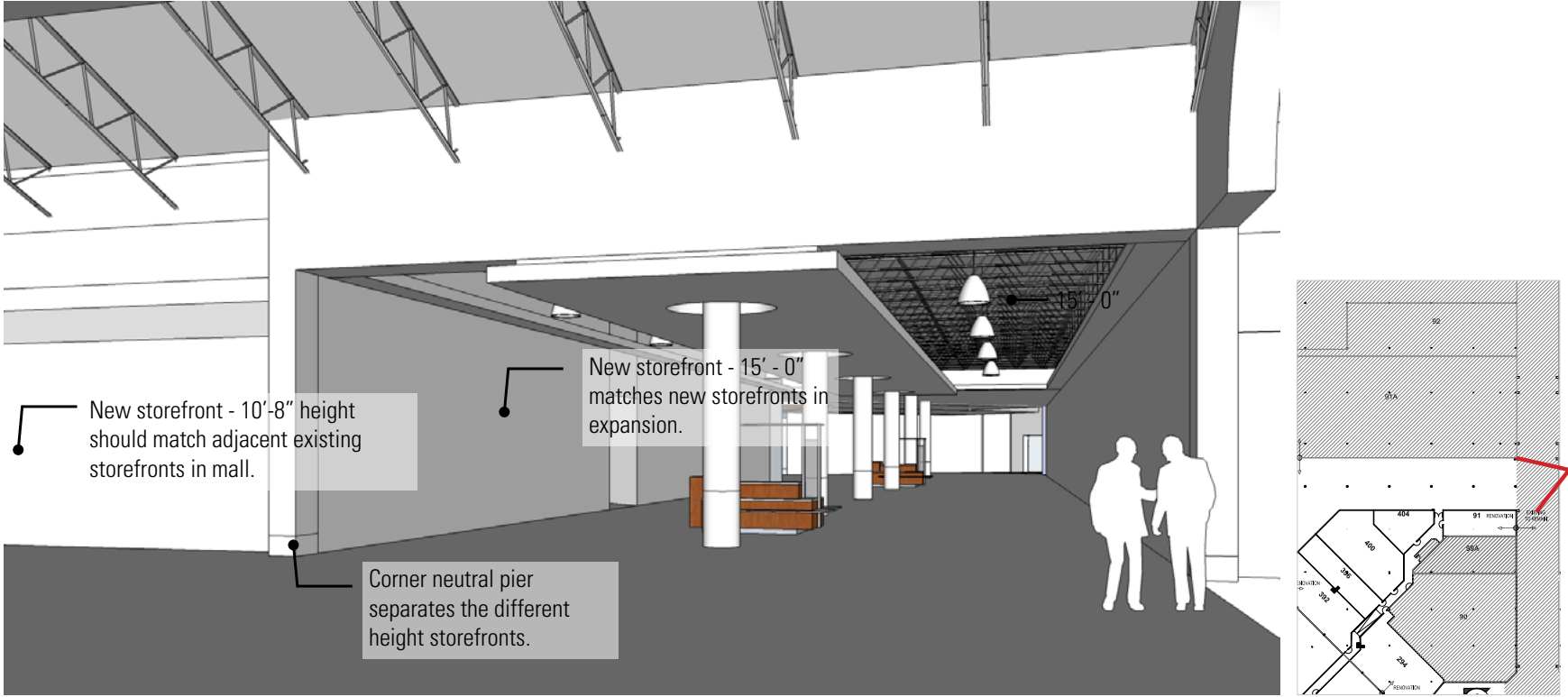

KNUCKLE TRANSITION (P6)

FASHION OUTLETS OF NIAGARA FALLS

CONTINUED

KNUCKLE TRANSITION (P6)

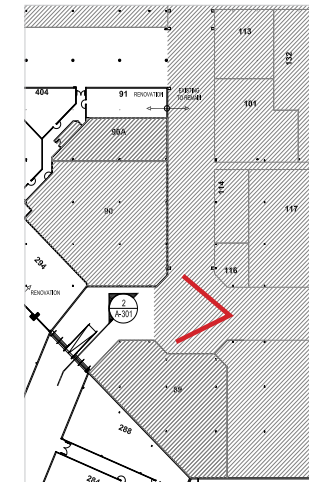
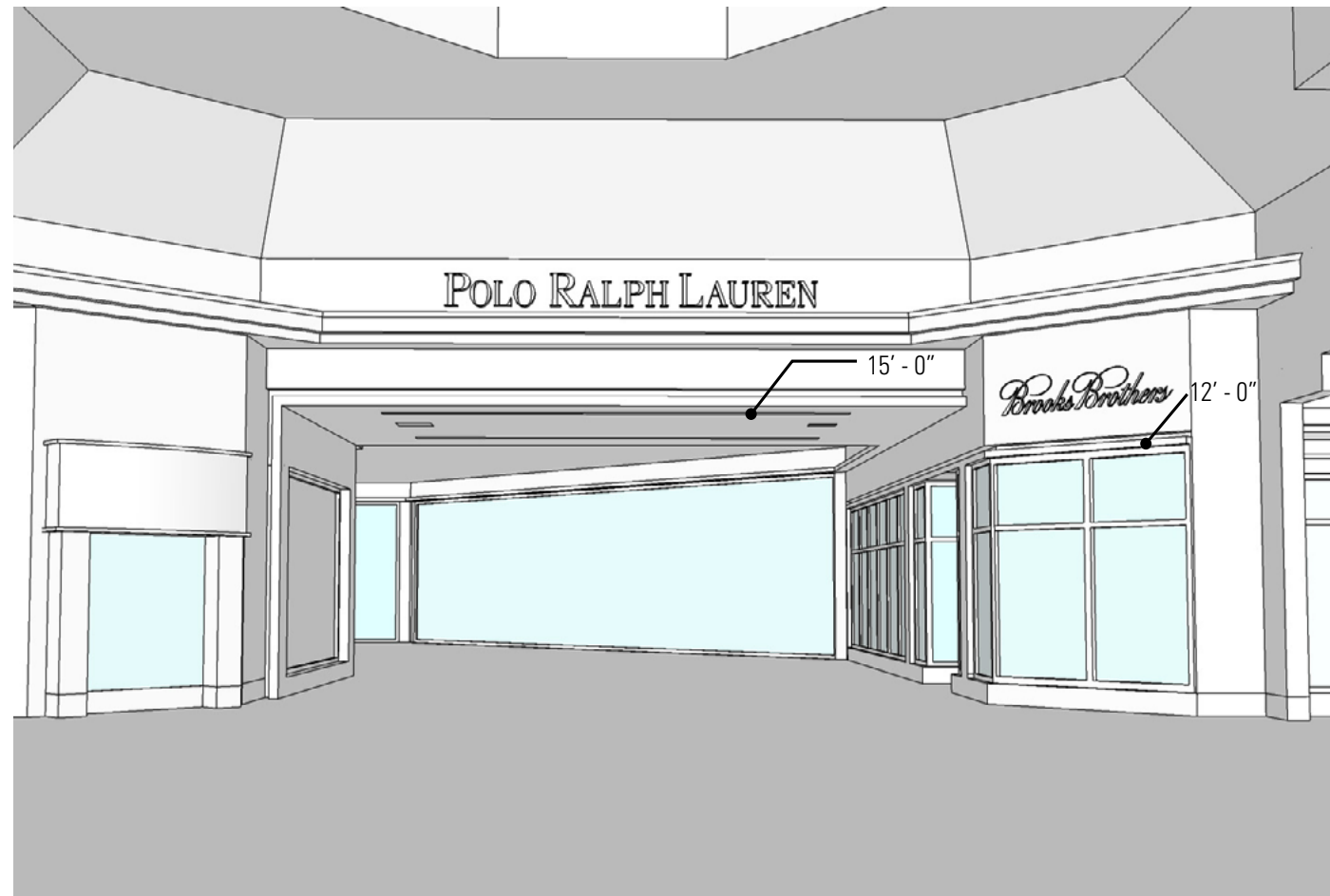

TYPICAL MALL (P7)

FASHION OUTLETS OF NIAGARA FALLS

CONTINUED

TYPICAL MALL (P7)



TYPICAL ELEVATIONS / SECTIONS

FASHION OUTLETS OF NIAGARA FALLS

TYPICAL ELEVATIONS / SECTIONS

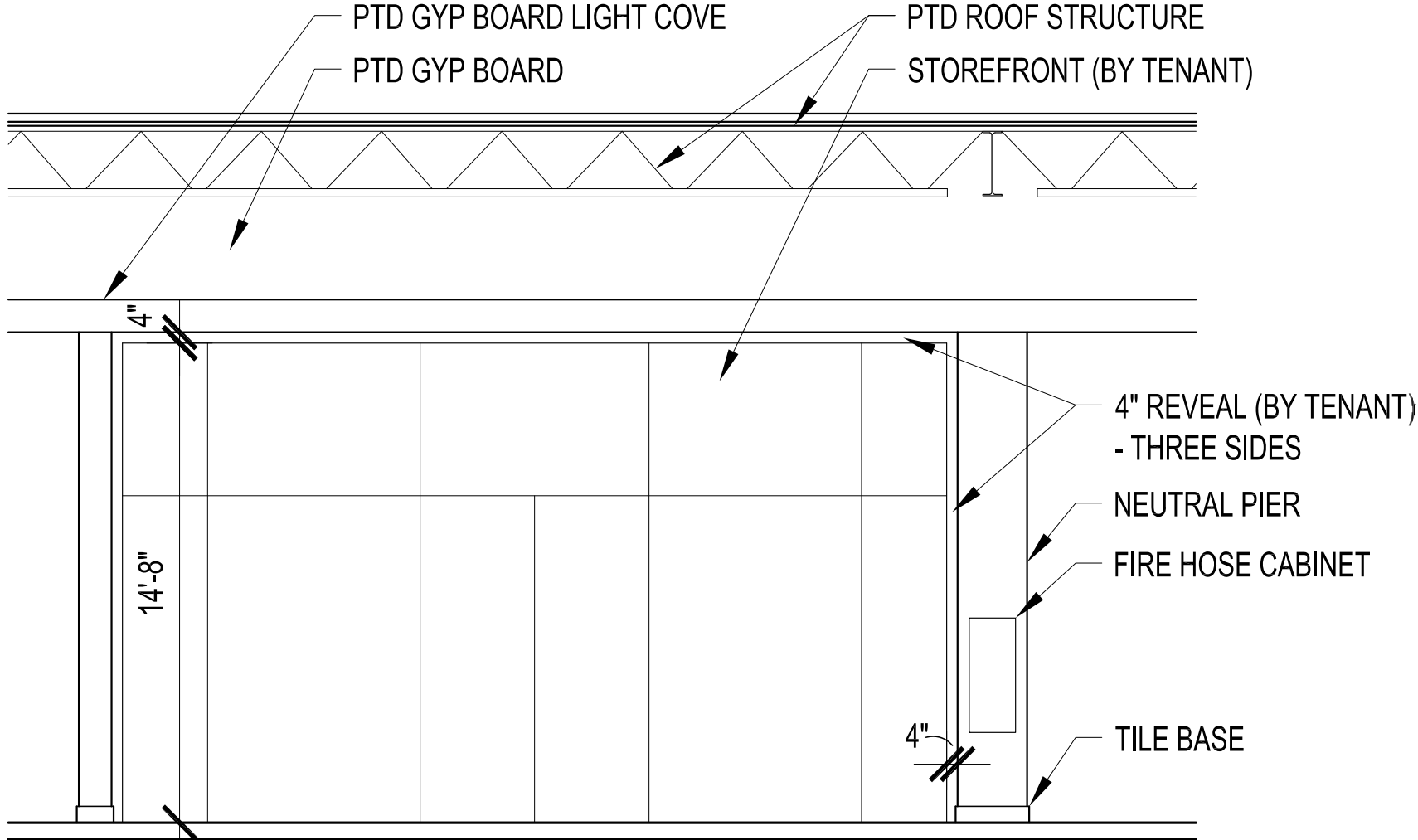

TYPICAL ELEVATIONS / SECTIONS

TYPICAL ELEVATIONS / SECTIONS (cont'd)

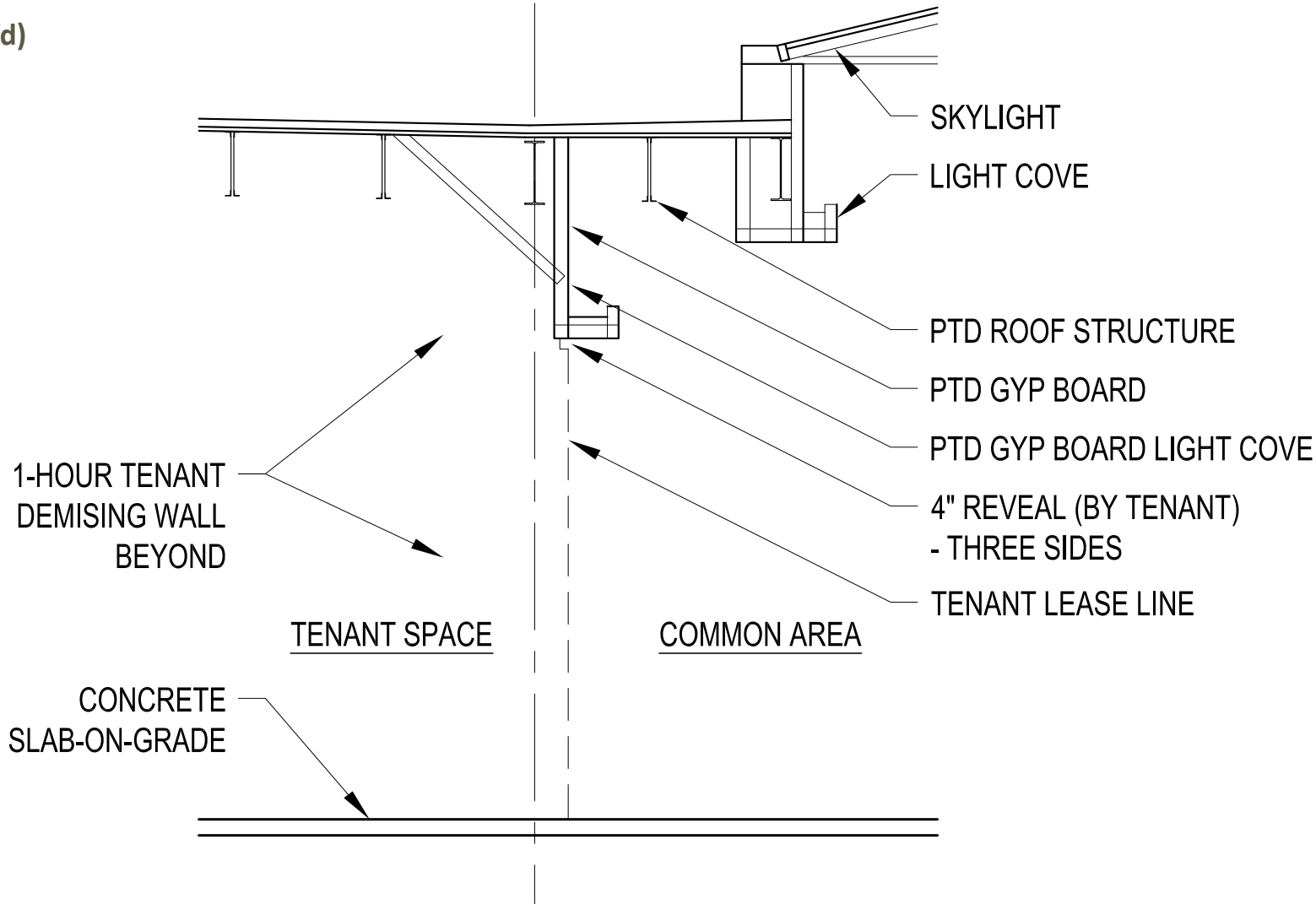

EXISTING CONDITIONS DIAGRAM

FASHION OUTLETS OF NIAGARA FALLS

EXISTING CONDITIONS DIAGRAM

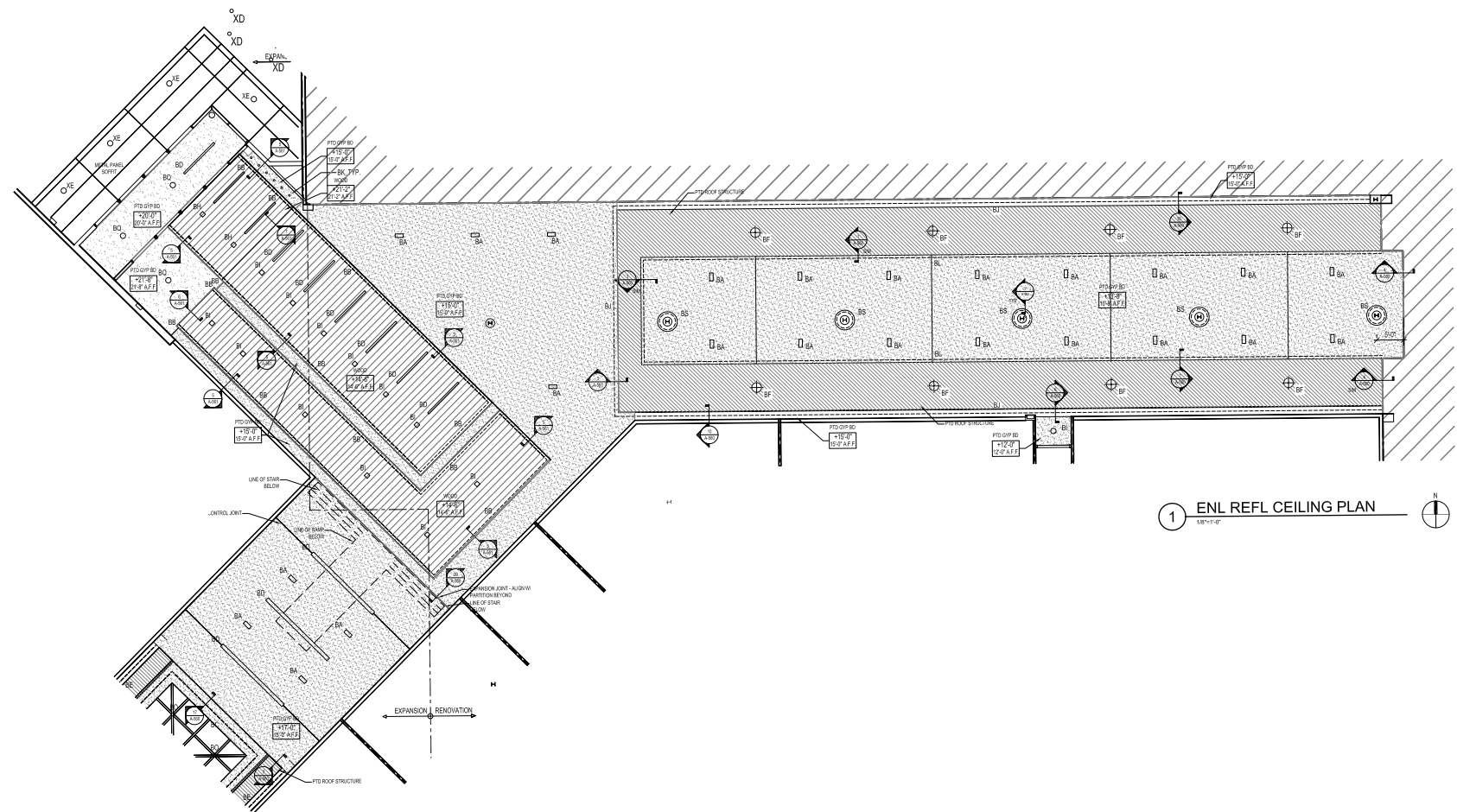

EXISTING CONDITIONS DIAGRAM

FASHION OUTLETS OF NIAGARA FALLS

CONTINUED

EXISTING CONDITIONS DIAGRAM (cont'd)

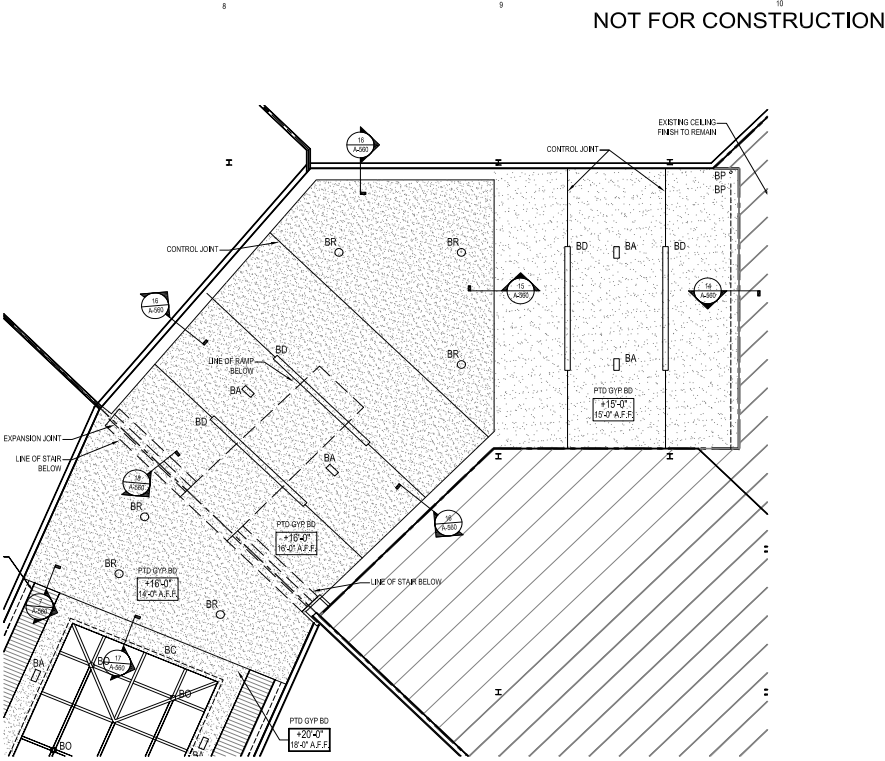
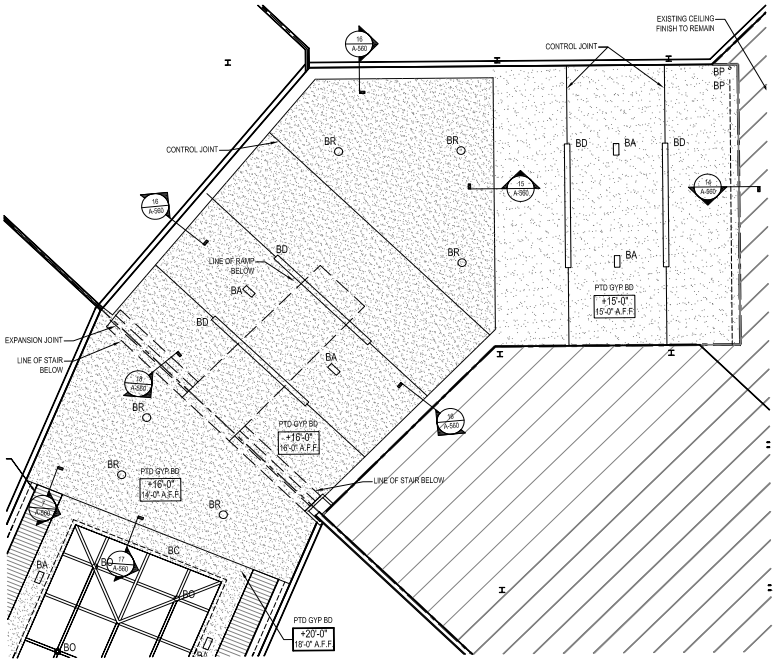

STOREFRONT DESIGN CRITERIA

FASHION OUTLETS OF NIAGARA FALLS

Materials used in the construction of storefronts shall be high quality, durable, authentically portrayed and code compliant. The entire storefront area is subject to the Landlord's scrutiny for quality of finishes, detailing and construction methods.

The success of the storefront design is largely dependent on how creatively materials and design details are used to develop a unique, but well executed image for each Tenant. The following are minimum standards for the use and installation of materials for storefront construction. Proposed materials and colors are to be submitted on a color material sample board to the Landlord for review during the preliminary design review process. (Refer to PLAN SUBMITTAL & REVIEW PROCEDURES for more detailed requirements.)

Required Storefront Elements

A. Entry

The entry shall involve more than the door alone. Doors shall be framed by architectural elements or framed by fenestration and details to create a sense of the entry point and invitation. This assembly of architectural entry elements forms the entry portal or recessed entry vestibule.

- Doors may not swing beyond the Lease Line and into the common area public circulation.
- Minimum 3' deep recessed entries are required for out swinging doors. The recessed entry area creates a vestibule with display zone fenestration on either side.
- The vestibule may become a larger construction or entry portal when the construction extends beyond the Lease Line into the Common Area or pops up above the Landlord's bulkhead or light cove.

- The entry construction may not be closer than 4'-0" to the demising pier. A minimum 4' display window is required between the entry and the demising pier.
- The Tenant's tile floor finish is required to be brought to the entry threshold within the vestibule or portal.

B. Door Types

- Swinging entry doors are required. The Tenant is allowed one pair of main entrance doors per elevation.
- Rolling grilles or sliding doors of any kind are not allowed.
- Frameless glass or custom doors are encouraged.
- Glazing is required in all door types and may be embellished with multiple panes, etching, or decorative glass.
- Doors are to be 8'-0" minimal height.

STOREFRONT DESIGN CRITERIA

C. Windows and Glazing

1. All glazing design for storefront is not allowed. Min 15-30% of storefront must be hard surface material. Refer to approved material list of this manual for more information.
2. Large panes of glazing must be of sufficient thickness to meet code and be properly supported.
3. All glass shall be tempered.
4. Stained, leaded, etched, beveled, fritted, glass block and other types of innovative glazing are encouraged.
5. In frameless assemblies, glass panel joint details must be top quality and are subject to strict Landlord review. Glazing edges must be polished, ground or chamfered. Glazing channels at corner conditions must be mitered.
6. Tenants may be required to provide seismic clips to stabilize tall expanses of glass. Silicone sealant at glazing joints is not permitted.
7. Reflective glass (including the extensive use of mirror) and/or tinted glass is not permitted on storefronts or in the storefront entry zone.
8. Tenants are not restricted to asymmetrical design, particular proportions, sizes or types of glazing systems.
9. Tenants are encouraged to “open-up” their storefront by extending their glazing to the extents of their lease-line.
10. Butt-joint glazing is encouraged for show windows that infill larger storefront forms. Glass shall be clear polished plate or tempered glass as required by code.
11. Window mullions are required to meet all material and finish standards.
12. Glazing should be predominantly clear to emphasize merchandise display.
13. Decorative glazing such as colored, beveled, sandblasted or etched glass may be used to create accent pattern and interest.
14. All glazing must meet code requirements.
15. Sections of glass are to be installed so that corners and abutting sections have no sash material providing separation or support.
16. Weather tight conditions must be maintained for exterior glazing.
17. No reflective or tinted glass will be allowed.
18. Minimum 6” durable base along entire storefront length is required.

STOREFRONT DESIGN CRITERIA

FASHION OUTLETS OF NIAGARA FALLS

CONTINUED

OTHER STOREFRONT ELEMENTS

Awning Type

Creative materials and forms of awnings are encouraged to promote identity among Tenants.

- Creative, imaginative, unusual shapes
- Semi-spherical
- Multiple awnings
- Unusual materials (such as louvers, wood, wire, metal, etc.) are subject to review by Landlord's Tenant Coordinator

Projections or awnings, where required, must be three-dimensional, emphasizing creative, dynamic forms and designs.

Awnings will be considered on a case by case basis depending on location in the Mall.



Awning Signage

Signage may be incorporated into the awning design which may be painted, silk-screened or integrated within the awning itself. The signage should be proportional to the awning size so that it does not clash or overpower the structure. Wording shall include Tenant's name and/or logo only. Tag lines will not be permitted.

Awning Logos

Logos are highly encouraged on awnings. Symbols applied to awnings provide a highly effective method of Tenant identity while adding color and interest to the storefront design. Logos should be silk-screened or painted when on a fabric awning. Three-dimensional 'medallion type' logos should be integrated when the awning is designed out of glass and/or metal. Size of logo should be proportional to the overall size of the awning, subject to Landlord approval. Logo shall be submitted along with awning and signage shop drawings.

- The lowest point of any awning or shade element shall be 8'-0" above the finished floor. It is the designer's responsibility to ensure that awnings conform to all applicable codes.
- Awning framework should be painted to match the awning fabric.
- Materials such as plastic or vinyl will not be permitted. In no case shall awnings be enclosed on the underside and internally illuminated, allowing the awning to function as a canned light source.
- Awnings must be cleaned and maintained in good condition by Tenant at Tenant's expense.

STOREFRONT DESIGN CRITERIA

FASHION OUTLETS OF NIAGARA FALLS

CONTINUED

OVERHANGS

Overhangs are permitted in storefronts provided that they are an integral part of the storefront design. The underside of overhangs must be articulated with architectural elements such as brackets, coffers or exposed beam-ends.



UMBRELLAS

Umbrellas are only allowed in the Tenant's exterior Leased Premises and cannot overhang into the public right-of-way. Umbrellas should be small in scale (maximum 6'-0" in diameter) and no more than 9'-0" high at the peak. Wood or wrought iron are the only acceptable materials for the umbrella structure. No insignia, graphics or text is permitted on the umbrella fabric. The umbrella fabric must be flame retardant material in a color approved by Landlord's Tenant Coordinator.



NEUTRAL PIERS DETAILS

FASHION OUTLETS OF NIAGARA FALLS

Demising Pier

Demising piers are located between each interior Tenant storefront and are centered on the demising partition. The pier is the same height as the Tenant storefront. The face of the pier projects beyond the Lease line and is located in plan between the Lease Line and the outside edge of the Landlord's bulkhead. Neutral pier details are identified on the following pages. The Landlord's finishes wrap the pier back to the Tenant's Lease Line.

- The Tenant's storefront system shall abut the side of the pier at the Lease Line.
- Landlord finishes are to be protected and restored if damaged by the Tenant.

NEUTRAL PIER CONDITIONS NORTH

FASHION OUTLETS OF NIAGARA FALLS

CONTINUED

NEUTRAL PIER CONDITIONS (NORTH)

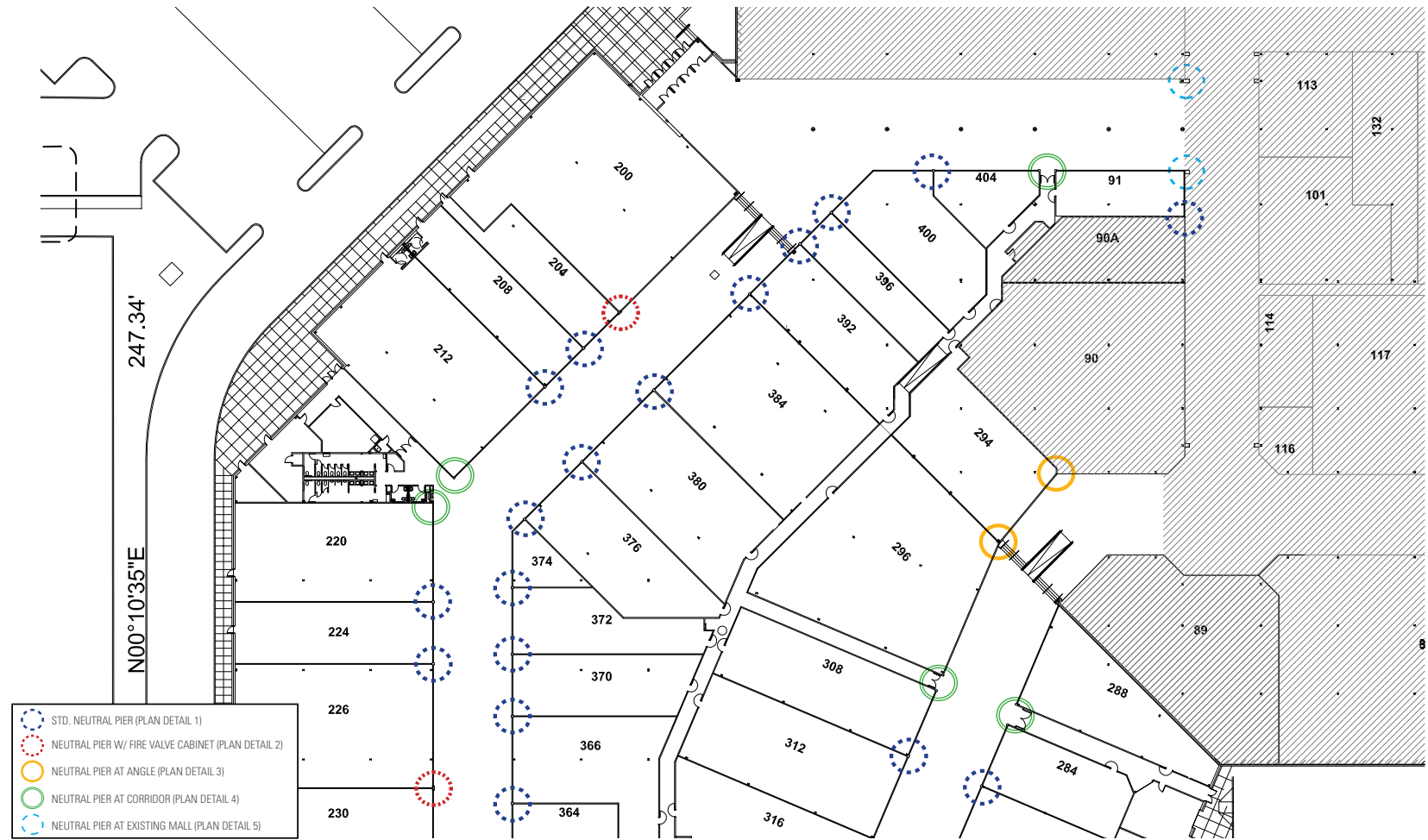

NEUTRAL PIER CONDITIONS SOUTH

FASHION OUTLETS OF NIAGARA FALLS



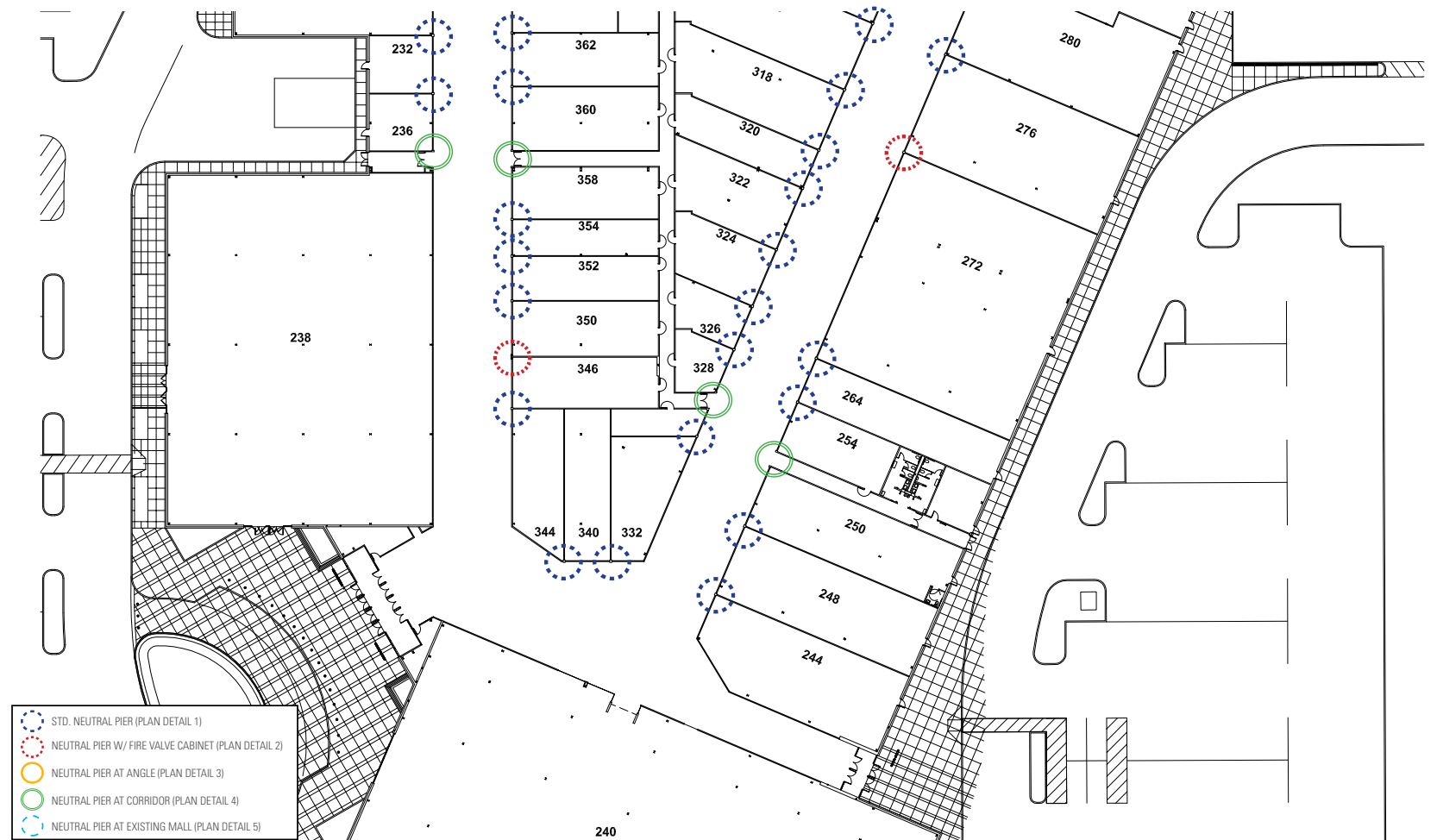

CONTINUED

NEUTRAL PIER CONDITIONS (SOUTH)



NEUTRAL PIER PLAN DETAILS

NEUTRAL PIER PLAN DETAILS

-  STD. NEUTRAL PIER (PLAN DETAIL 1)
-  NEUTRAL PIER W/ FIRE VALVE CABINET (PLAN DETAIL 2)
-  NEUTRAL PIER AT ANGLE (PLAN DETAIL 3)
-  NEUTRAL PIER AT CORRIDOR (PLAN DETAIL 4)
-  NEUTRAL PIER AT EXISTING MALL (PLAN DETAIL 5)

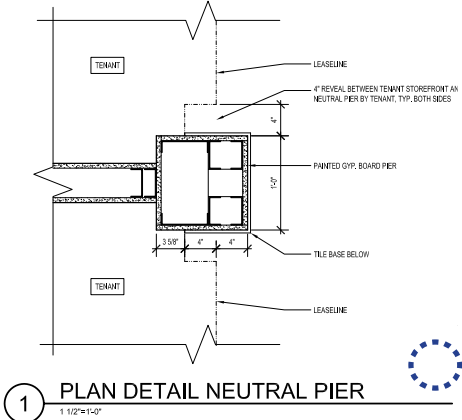
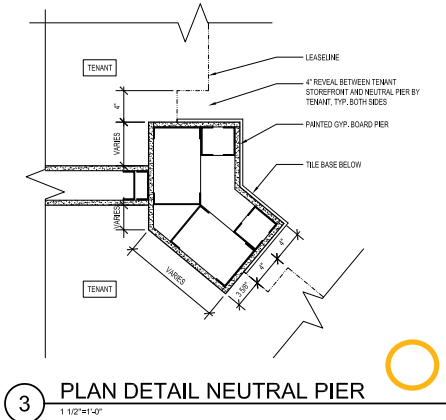
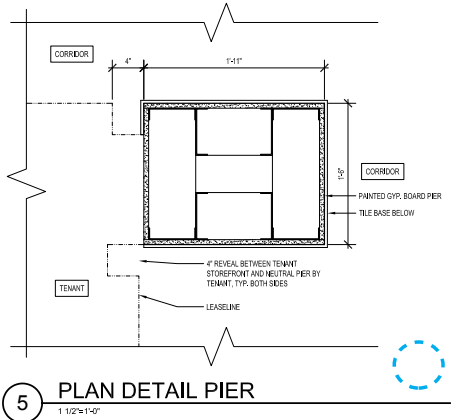
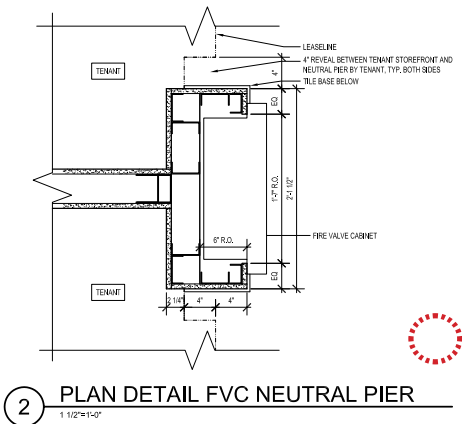
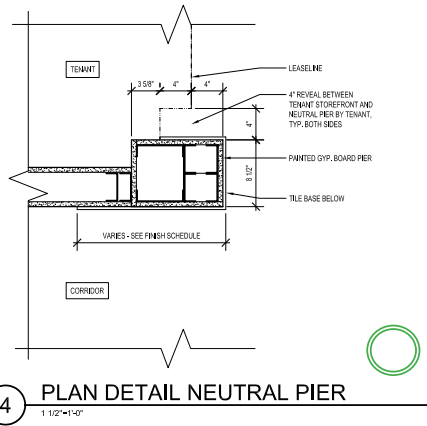

GENERAL MATERIAL REQUIREMENTS

- The use of natural materials is encouraged. All materials used in storefronts must be durable and non-corrosive.
- Careful attention to the detailing or joinery of differing materials is necessary. A carefully defined edge must be established between different materials and surfaces on the storefront as well as between the Tenant and Landlord finishes.
- All finished store materials within 6'-0" of the storefront point of closure shall be durable such as glass, tile, metal, stone, terrazzo, plaster, hardwood or similar materials approved by the Landlord. Reflective wallpaper, vinyl wall coverings, plastic laminates, mirror, slatwall or tambour will not be permitted.
- Any wood material used for storefront construction must comply with all code requirements.

Metals

All storefront metal panels must meet LL requirements below (this note must appear on final drawing set):

- All seams between metal panels must be identified on the storefront elevation and must be properly addressed during design review process. Metal panels will not be allowed to directly come into contact with adjacent panel. Reveals, turn-in seams, welding or

similar must be specified and detailed out on the plans for approval.

- No visible fasteners.
- Min ½" thick fire-rated plywood substrate is required and must be called out on the plans.
- Minimum 18 gauge metal panels are required. This must be called out on their plans for approval.
- High quality is expected for all metal applications. Metal such as shop-painted aluminum and steel, stainless steel, solid brass, bronze, pewter or enamel coated steel may be used for hardware, trim and panels when well designed and detailed.
- Lap joints and seams must be even and straight and concealed when possible. Outside corners are to be mitered or continuous break shaped.
- Fabrication must be either heavy gauge material or thinner gauge material shop laminated to solid backing. In no case is oil canning (resulting from light reflection from an uneven or buckled surface), scratches, warps, dents, occlusions, visible seams or other imperfections allowed.
- Sealants on natural metals are required to prevent tarnishing and must be maintained by Tenant at Tenant's expense.

- Textured or brushed stainless steel, galvanized, sandblasted and etched metals are encouraged in creative applications.
- Unique treatments such as patina, rusted, etched and imprinted metals will be considered for special design objectives.
- Polished metals should be solid, not plated and limited to accent trim.
- Simulated finishes such as metallic laminates and anodized aluminum are not permitted.

Stone

Granite, marble, limestone, slate, adoquin and other natural stone materials may be used in storefront applications. Stone may be polished, unpolished, sandblasted, flamed, honed, split-face or carved. Careful craftsman-like attention to detail is required at all connections and transitions to other materials.

- Edge details must prevent visible unfinished edges. Exposed edges must be quirk mitered, chamfered or polished to match adjacent surface finish.
- The transition between stone and adjoining materials must be defined by use of metal reveals.

Stone (cont'd)

- Stone used as a paving material must be flush when meeting other flooring materials.
- Natural stone must be protected against staining and discoloration by means of sealers appropriate to the material.

Wood

Painted or stained wood may be used in many design applications, such as window frames, decorative trim or molding and for solid areas, such as decorative bulkheads. In some cases, it may be used for larger architectural elements, such as columns and entablatures. Wood paneling and plank construction are not acceptable unless presented in a highly imaginative concept and approved by the Landlord.

- All detailing and construction is to be executed in a high quality, craftsman-like manner.
- Wood used in the construction of the storefront must be kiln dried, mill quality hardwood and must meet local flame spread requirements (Class III 76-200).
- Painted wood must have a shop quality enamel finish.
- Wood without a paint finish must receive a clear, preservative sealant.

- Extensive use of natural wood finishes is discouraged. All stains and finishes must be approved by Landlord's Tenant Coordinator.

Tile

Tile may be used in diverse applications. Its use is encouraged to introduce light, decorative texture or graphic quality to a storefront.

- Porcelain, ceramic or glass tiles in glazed or natural finishes may be used as accents and in limited field applications. Patterns used over large areas are expected to have a sophisticated, well executed design concept.
- Small and intricate mosaic tile patterns may be utilized for detail and accent only.
- All tile must be carefully detailed at outside corners with bull nose edges or special corner trims. Lapped or butt joints are not permitted.
- Grout color should match the background color of the tile so as not to emphasize a grid pattern.

Pre-cast Stone and Concrete

Many pre-cast stone and concrete products are currently available that may be acceptable for storefront applications. The use of these materials is at the discretion of the Landlord.

Plaster

Plaster, cement plaster (stucco) and Venetian plaster finishes may be considered for limited storefront applications, provided the finish texture is a light dash, sand or smooth finish. Plaster or stucco finishes should be used in combination with other high quality materials such as stone or metal and not be the primary storefront material.

Faux Finishes

Faux finishes may be used at the Landlord's discretion.

- Actual samples of the faux finish must be submitted to the Landlord. Photographs of previous examples are helpful but may not be substituted for an actual sample.
- Faux finishes must be executed by a commercial artisan specializing in that medium.

Painted Surfaces

Any paint applied to the materials in the storefront is to be specified and is under the approval of the Landlord's Design Consultant. All paint should be of high quality for an even and durable finish. The following criteria must also be observed:

- Painted wood surfaces must be properly prepared and sealed prior to the application of a high grade enamel.

Painted Surfaces (cont'd)

- Painted metal shall have a factory applied finish of baked enamel or powder coat treatment.
- Painted gypsum wall board will be allowed only within the interior of the storefront, not on the exterior storefront.
- Required MDF finish process:
 - 1 Coat primer, 2 coats finish (sprayed and sand between each step).
 - * Specify drywall behind the MDF
 - Min. thickness for MDF is ¾" on storefronts.

Prohibited Materials

The following is a list of prohibited materials. In rare instances, special consideration may be given for the use of a prohibited material if its application is highly original, creative and essential to the theme or design concept of the storefront. Exceptions will be determined by the Landlord during design review:

- Plastic laminates; Plastic spandrel panels or applied plastic laminated materials
- Glossy or large expanses of acrylic or Plexiglas
- Pegboard

- Mirror
- Highly polished or plated metals - except as trim
- Reflective glass
- Simulated materials such as brick, stone or wood veneer
- Distressed woods such as pecky cedar, rough sawn lumber, softwoods
- Anodized aluminum
- Vinyl, fabric or paper wall coverings
- Plywood or particle board
- Sheet or modular vinyl
- Luminous ceilings, including "egg crate"
- Vinyl awnings
- Shingles, shakes, rustic siding
- 4"x4", 6"x6", 12"x12" tiles
- Glazed tiles
- Other materials deemed unacceptable by the Landlord

Tenants are required to produce high quality, well detailed and executed interior solutions that are unique, imaginative and stylized.

The store interior is typically viewed as a continuation of the storefront in design and materials. Walls are to have modulation of display systems and built in architectural components that reinforce the store design theme.

Tenants with above normal sound levels must provide sound isolation in demising walls, floor, ceiling including pipes, conduits and wires must be designed so that in no event shall tenant noise emit sounds and/or vibrations which would cause the ambient noise level anywhere in the adjoining premises to be increased by more than 3 dBA during the adjoining space operating hours or (ii) which would cause the vibration level in the adjoining space to be more than 70 vdB during the adjacent premises store operating hours, or (iii) which can be unreasonably experienced in the Common Area.

The Landlord will strictly enforce all Tenant's right to quiet enjoyment of their Leased Premises.

Design Control Area (DCA)

The DCA is the area at the front of the Tenant space that extends from the point of closure to all points 6'-0" into the space. The DCA includes all display windows and retail graphics, display fixtures, signs, materials, finishes, color and lighting fixtures within the area.

The DCA can be considered an extension of the storefront presentation and should convey a store's merchandise identity and generate activity. It should

convey excitement and give the consumer a reason to stop at the store. Proportion and scale of objects within the DCA is a specific concern in successful design. As with the actual storefront design, the objects within it must be in proportion to the space around them. Incorporating elements that raise from the floor or lower from the ceiling can control the scale of the DCA. Pedestals to display merchandise or light pendants hanging down can be examples of object forms that can control scale. These solutions can vary and are somewhat different from traditional and typical display zones.

Tenants shall use the following design criteria for displays within the DCA:

- Design drawings shall have a display layout plan. The layout plan shall have cut sheets for fixture and/or mannequin types and include photographs of any existing storefronts a Tenant may have that will enhance the layout plan. A rendering is required if photographs are not available.
- Displays shall be deliberate and designated as integrated elements of the storefront.
- Security devices must be concealed; freestanding pedestals are not permitted.
- Large temporary signs for special sales or clearances shall not be hung in the DCA including any signs taped or suction cupped to storefront glazing.
- No pegboard, slatwall or metal shelving of any kind may be placed in or extend into any part of the DCA.

Ceilings

Tenants can choose to have an open ceiling which may incorporate an open grid or be painted. Tenant installed ceilings shall conform to the following criteria:

- Hard surface ceiling required through the entire storefront DCA. This distance shall be a minimum width of 6'-0" in from the innermost point of closure line.
- Custom ceiling treatments are required. Multi-level gypsum wallboard, concealed spline, decorative patterned ceiling panels and other "high-tech" materials are encouraged. The use of ceilings on a single plane is not permitted. The use of beams, steps and 'islands' are required along with the imaginative use of lighting fixtures and fittings.
- Fire sprinkler heads are to be fully recessed in hard or acoustical ceilings.
- Standard 24" x 48" acoustical panels are not allowed in the sales area.
- Ceiling concepts implementing exposed structure, electrical and mechanical systems must be coordinated with the Landlord for specific technical and design requirements.
- All suspended ceilings shall stop within 2'-0" of the demising walls within the Tenant sales area. Suspended

ceilings shall be terminated with a soffit, cove lighting detail or other means of a finished edge along partition walls. Exposed edges shall be properly finished. Wall-to-wall suspended ceilings are not allowed.

- All ceilings, related framing, blocking and accessories shall be non-combustible. No combustible materials may be used above finished ceiling surfaces.

Lighting

Lighting can greatly contribute to the design of a Tenant's store, emphasizing architectural forms, highlighting signage and adding color and visual drama to walls and other design elements. The creative use of dramatic lighting is encouraged at entries, show windows and merchandise displays.

- The DCA of the Tenant space must employ lighting fixtures consistent with the character of the storefront design. All lighting fixtures within the DCA must be recessed downlights, MR16 low voltage or similar types. Fluorescent fixtures will not be permitted.
- Track lights shall be finished to match ceiling; other finishes to be approved by Landlord. Track heads are to be accommodated with shields or louvers. Track lights are not allowed in DCA.

- Fixtures must be positioned so that bright glare is not directed onto the public areas.
- All fluorescent, incandescent, LED and HID lighting fixtures in public Tenant areas, other than track and decorative fixtures, shall be recessed with no directly visible lamp sources.
- Bare lamp fluorescent or incandescent fixtures may be used only in concealed areas and/or stockrooms. Fluorescent fixtures shall have a maximum size of 2' x 2' and have silver parabolic louvers or metallic finished eggcrate diffusers. All lighting fixtures shall bear the U.L. label.
- Concealed light coves to highlight architectural elements within the storefront are highly encouraged.
- Wall sconces may be used to cast light onto storefront forms, provided that bare bulbs are not exposed and that the finish and form of these fixtures coordinate with the overall storefront design. Fixture cut sheets will be required to be submitted if this light form is used.
- Exterior mounted decorative light fixtures are encouraged where appropriate for the storefront design concept. Fixture cut sheets must be submitted for review.

Lighting (cont'd)

- All lighting must be reviewed and approved by Landlord. Tenant is responsible for maintenance of all lighting within the entire Leased Premises.
- Tenant shall comply with all applicable energy conservation and building codes.
- No strobe, spinner or chase type lighting shall be used.
- All showcases and display cases must be adequately lit and ventilated. Direct visual exposure of incandescent bulbs and/or fluorescent tubes is prohibited.

Walls/Partitions

Demising walls may be provided between two Tenants and/or Tenant and exit/service corridors. Walls will typically consist of 3 $\frac{5}{8}$ " or 6" metal studs (provided by Landlord), and $\frac{5}{8}$ ", type X fire rated drywall, taped from floor to bottom of roof deck, or deck above (or as required by governing code) on each side (provided by Tenants). At Landlord's option, demising partitions shall be of unfinished masonry, concrete or metal studs. Demising walls are not designed to accommodate cantilevered or eccentric loads. If Tenant plans to use a demising wall for support of shelf standards, light soffits or heavy attachments, Tenant shall reinforce the wall as required by providing additional steel studs or independent supports for the shelf standards.

- Existing corridor separation walls adjacent to Tenant's space have finishes by the Landlord on the corridor side only. Tenant shall finish the interior as required by code for fire rated wall.
- Demising walls and ceiling shall be sound insulated to achieve a minimum STC rating of 50 by Tenants who produce above 80 dB (including but not limited to music stores, arcades, etc.). The Landlord will strictly enforce all Tenant's right to quiet enjoyment of their Leased Premises.
- Tenant shall protect fire proofed columns and braces with gypsum board, and furr as required.
- The following are required for hair salons, pet shops and all food preparation type Tenants:
 - a. Walls containing "wet" areas to be constructed of metal studs with water resistant $\frac{5}{8}$ " type "x" gypsum board.
 - b. Demising walls of pet shops shall have sheet metal installed on studs, behind drywall, up 3'-0" from floor.
- Tenant Premises adjacent to a two-hour wall condition will be required to apply two (2) layers of $\frac{5}{8}$ " type "x" gypsum board or other material to adequately complete the wall construction to provide a two-hour rating.
- Stockroom Partitions. When Tenant chooses not to install a ceiling within Tenant's stockroom, Tenant shall extend the partition separating the stockroom from other areas of the store, to the underside of the structure above in order to isolate the stockroom from the sales area attic space. Tenant to verify if this is allowed by code.
- Wall Finishes. All interior wall surfaces must be finished in an appropriate manner and be in compliance with all applicable codes. All Tenant space interior wall finishes are to meet a Class III flame spread rating or as required by local code.
- Metal or plastic laminate inserts are required for slatwall. No visible substrate at slats. Slatwall is not allowed within the first 8'-0" of store entry doors.
- Recessed wall standards are permitted. No open shelving with visible brackets or surface mounted systems are allowed.

Floor and Wall Base

- Tenants shall install a floor covering in Tenant's sales area which conform to the following criteria:
- Hard surface floor and base required through the entire DCA, including any permitted pop out areas. Carpet, vinyl or rubber materials of any sort will not be permitted within the DCA.
- Exposed concrete floors shall be sealed.
- Wood installations shall be hardwood with wear resistant surface.
- Ceramic, quarry and stone tile installations must be commercial grade with non-slip surface.
- Carpet must be commercial grade and must have proper fire ratings to meet local codes. Carpeting will not be permitted where color, quality or weave is not suitable for high traffic areas. Note: Carpet may not be used at the store entry within the DCA.
- Sheet or modular vinyl may be used in support or stock rooms not visible from the sales area.

- Tenant shall provide a transition strip between opposing floor finishes. This includes, but is not limited to carpet and wood or carpet and tile.
- Tenant shall provide wood base in sales area.
- Any floor materials other than those mentioned above will not be allowed. Samples of all finishes must be submitted for approval and included in Tenant's preliminary submissions.

Toilet Room Requirements

- Toilet facilities shall be designed in compliance with all applicable ADA & Building Department Codes.
- Provide a 3" floor drain and cleanout.
- Each restroom must have an exhaust system.
- Floor finishes in toilet rooms shall be ceramic tile with a coved 6" base. Tenant is required to provide a waterproof membrane beneath the finish floor surface up to a height of 4" along all walls.
- Toilet room walls and ceiling shall be constructed of metal studs with water-resistant 5/8" type "x" gypsum

board applied to the interior side of the toilet room. At a minimum, interior wall finishes shall be a light colored enamel paint with a 4'-0" high wainscot extending 24" on each side of, and 24" beyond the front portion of any water closet or urinal.

- The ceiling shall be a minimum of 8'-0" above the finished floor level, be constructed of 5/8" type "x" water resistant gypsum and be finished with enamel paint. The ceiling shall contain a vent, which shall be connected to the Landlord's exhaust system or as pursuant to the Center requirements.
- Water shut-off valve at eye level.